

Normas de Referência

Construção

ASME B 16.34

Testes

API 598

Conexões

ROSCA BSP - ISO 228

ROSCA NPT - ANSI/ASME 1.20.1

SOLDA SW - ASME B16.11

SOLDA BW - ASME B16.25

Materiais

Corpo e Tampas

ASTM A 216 - WCB

ASTM A 351 - CF8

ASTM A 351 - CF8M

Esfera

ASTM A 351 - CF8

ASTM A 351 - CF8M

ASTM A 217 - CA 15

ICI 416

Vedações

PTFE

COMP L

Haste

ASTM A 276 - 304

ASTM A 276 - 316

SAE 1020

ASTM A 276 - 410

ASTM A 582 - 416



Desenho Técnico

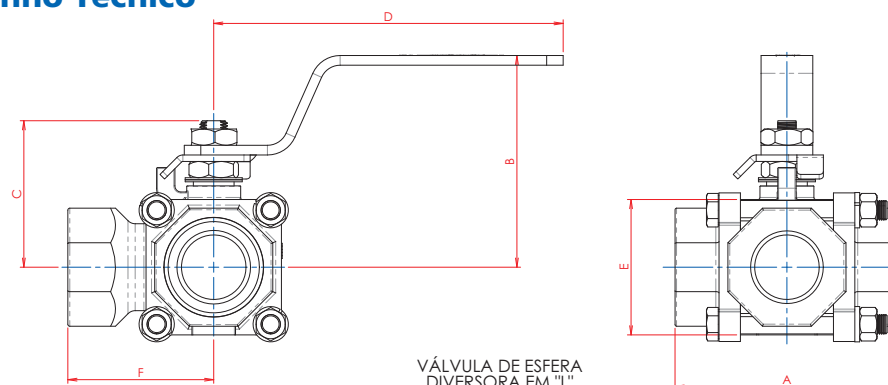

TIPOS DE CONEXÕES

ENCAIXE DE SOLDA SW

ROSCA BSP OU NPT

ENCAIXE DE SOLDA BW

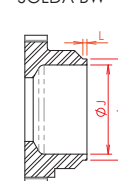
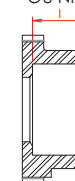
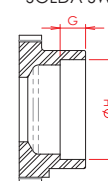

VÁLVULA DE ESFERA DIRECIONAL PASSAGEM REDUZIDA (PR)															
BITOLA		PASS.	A	B	C	D	E	F	G	H	I	J	K	L	PESO kg
POL.	DN														
1/2"	15	11,1	62,0	46,0	39,0	125,0	43,5	47,0	9,5	21,8	17,0	15,8	21,8	2,0	0,562
3/4"	20	14,0	71,6	48,0	41,0	125,0	48,0	51,8	12,5	27,1	17,0	20,9	27,1	2,0	0,699
1"	25	20,4	88,6	82,0	51,0	165,0	57,0	56,4	12,5	33,8	23,0	26,4	33,8	2,0	1,200
1.1/4"	32	25,4	101,0	86,0	60,0	165,0	64,0	67,0	12,5	42,6	23,0	35,0	42,6	2,0	1,552
1.1/2"	40	31,7	111,7	110,0	73,0	170,0	73,0	71,7	12,5	48,7	28,0	41,0	48,7	3,0	2,468
2"	50	38,0	121,5	113,0	77,0	170,0	81,5	82,8	16,0	61,0	28,0	52,5	61,0	3,0	3,204
2.1/2"	65	50,8	138,8	125,0	86,0	256,0	94,0	101,0	16,0	73,8	28,0	62,7	73,8	3,0	5,030
3"	80	63,0	176,5	145,0	116,0	267,0	116,0	121,8	16,0	90,1	37,0	78,0	90,1	3,0	8,870

VÁLVULA DE ESFERA DIRECIONAL PASSAGEM PLENA (PP)															
BITOLA		PASS.	A	B	C	D	E	F	G	H	I	J	K	L	PESO kg
POL.	DN														
1/4"	8	11,1	62,0	46,0	39,0	125,0	43,5	47,0	9,5	14,0	11,0	9,3	14,0	2,0	0,584
3/8"	10	11,1	62,0	46,0	39,0	125,0	43,5	47,0	9,5	17,6	11,0	12,3	17,6	2,0	0,575
1/2"	15	14,0	71,5	48,0	41,0	125,0	48,0	51,8	9,5	21,8	17,0	15,8	21,8	2,0	0,731
3/4"	20	20,4	88,6	82,0	51,0	165,0	57,0	56,4	12,5	27,1	17,0	20,9	27,1	2,0	1,248
1"	25	25,4	101,0	86,0	60,0	165,0	64,0	67,0	12,5	33,8	23,0	26,4	33,8	2,0	1,557
1.1/4"	32	31,7	111,7	110,0	73,0	170,0	73,0	71,7	12,5	42,6	23,0	35,0	42,6	2,0	2,540
1.1/2"	40	38,0	121,5	113,0	77,0	170,0	81,5	82,8	12,5	48,7	28,0	41,0	48,7	3,0	3,431
2"	50	50,8	138,8	125,0	86,0	256,0	94,0	101,0	16,0	61,0	28,0	52,5	61,0	3,0	5,390
2.1/2"	65	63,0	176,5	145,0	116,0	267,0	116,0	121,8	16,0	73,8	28,0	62,7	73,8	3,0	9,320

A vazão apresentada em Kv (m³/h) corresponde a um diferencial de pressão (Δp) de 1 bar utilizando água como fluido de teste..

Especificações Técnicas

Válvula Direcional de fluxo Classe 300, disposta de uma entrada lateral ou inferior e, duas saídas utilizadas para desviar alternadamente o fluxo.

Construção tripartida (um corpo e duas tampas), facilitando a manutenção sem a necessidade de desconectar as extremidades da linha.

Haste à prova de expulsão.

Disponível na construção com dupla vedação, o que proporciona maior segurança quando utilizadas em linha de vapor.

Não indicada como válvula para bloqueio de fluxo.

De fácil aplicação para trava de cadeado.

TECNI-AR Ltda - Tel: fB13362-2400

k k w.tecni-ar.com.br