

# Welded Fittings

Catalog 4280  
Revised, February 2003



# Welded Fittings

## Introduction

In the chemical industry, process pressures are climbing higher and higher. The utility field, with its high steam pressures and hydraulic and pneumatic shutdown systems, demands the utmost in reliability. Nuclear power plants with their "hot" materials also have massive reliability problems. Such problem areas have given rise to the increased use of the permanent-weld-type tube fittings which provide a sturdy, tight integral line system that remains unaffected by shock, vibration or thermal distortion. The Parker Weld-lok® line of permanent socket weld tube fittings meets the most exacting requirements of any system.

## Heat Code Traceability

Parker Hannifin's Instrumentation Connectors Division offers Heat Code Traceability (HCT) on CPI™, A-LOK®, Instrumentation Pipe, Automatic Butt weld, and Weld-lok®.

HCT refers to the fact that a specific part can be traced back to the original mill heat of metal from which it was made. Beginning with the original melt, a package of documents is created which completely describes the metal in physical and chemical terms. The end result is that a number, which is permanently stamped to the part, refers back to the document package.

The HCT number is stamped on the material (bar stock or forging) prior to manufacturing. The concept is useful because it provides a method for complete material accountability for the manufacturer and end customer.

HCT offers these advantages:

- Raw materials for manufacture must meet code requirements. This can be verified through documentation so that the customer is certain that what is ordered is received.
- HCT provides a record of chemical analysis with the raw material. Thus, in areas requiring welding, the correct welding technique is applied.
- HCT relieves the user of Parker instrumentation tube fittings of any doubts. It acts as an assurance for today and for tomorrow.

The material used in Parker Hannifin instrumentation fitting components is 316 or 316L (welded products) stainless steel as specified and referenced in Section III of the ASME Boiler and Pressure Vessel code.

The American Society of Mechanical Engineers (ASME) Boiler and Vessel Code, Section III, latest issue, entitled Rules for Construction of Nuclear Power Plant Components, is the principal document covering this type of fitting in the nuclear field. ANSI Standard B.31.1, Power Piping, and ANSI Standard B.31.7, Nuclear Power Piping, are also important documents in the field.

In addition to the documentation of chemical and physical properties, great care is taken throughout the manufacture of Parker's tube fittings to ensure that potential stress corrosion will not be a problem in normal usage of the parts. Manufacturing processes avoid exposure of the parts to mercury or halogens, and control of thermal treatment avoids the condition known as continuous grain boundary carbide precipitation. (pg. 12)

**For additional information please contact your local authorized Parker Instrumentation distributor or call Parker Instrumentation Connectors Division and ask for Bulletin 4230-B15.**



### **WARNING**

FAILURE, IMPROPER SELECTION OR IMPROPER USE OF THE PRODUCTS AND/OR SYSTEMS DESCRIBED HEREIN OR RELATED ITEMS CAN CAUSE DEATH, PERSONAL INJURY AND PROPERTY DAMAGE.

This document and other information from Parker Hannifin Corporation, its subsidiaries and authorized distributors provide product and/or system options for further investigation by users having technical expertise. It is important that you analyze all aspects of your application and review the information concerning the product or system in the current product catalog. Due to the variety of operating conditions and applications for these products or systems, the user, through its own analysis and testing, is solely responsible for making the final selection of the products and systems and assuring that all performance, safety and warning requirements of the application are met.

The products described herein, including without limitation, product features, specifications, designs, availability and pricing, are subject to change by Parker Hannifin Corporation and its subsidiaries at any time without notice.

### **Offer of Sale**

The items described in this document are hereby offered for sale by Parker Hannifin Corporation, its subsidiaries or its authorized distributors. This offer and its acceptance are governed by the provisions stated in the "Offer of Sale".

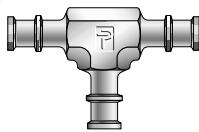
## Visual Index

### Automatic Butt Weld Fittings

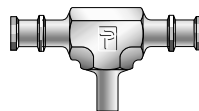
**Automatic Butt Weld Union**  
YHY  
page 7



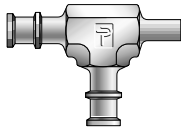
**Automatic Butt Weld Union Tee**  
YJY  
page 7



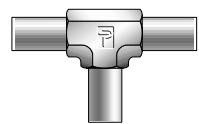
**Automatic Butt Weld Manifold Branch Tee**  
YJT3  
page 7



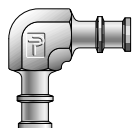
**Automatic Butt Weld Manifold Run Tee**  
YJT3Y  
page 8



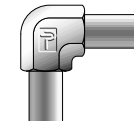
**Automatic Tube Butt Weld Manifold Tee**  
T3JT3  
page 8



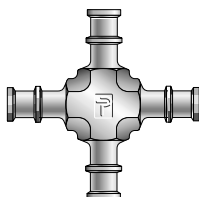
**Automatic Butt Weld Union Elbow**  
YEY  
page 9



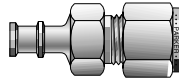
**Automatic Tube Butt Weld Manifold Elbow**  
T3ET3  
page 9



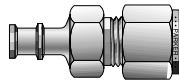
**Automatic Butt Weld Cross**  
YKY  
page 10



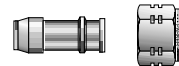
**Automatic Butt Weld to CPI™ Tube Union**  
YHBZ  
page 10



**Automatic Butt Weld to A-LOK® Tube Union**  
YHLZ  
page 10



**Automatic Butt Weld Adapter to Compression Port Connector**  
ZPY & BY  
page 11



**Automatic Butt Weld Plug**  
PNY  
page 11

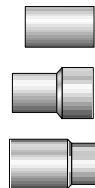


### Weld-lok® Socket Weld Tube Fittings

**Union**  
HW  
page 14



**Tube Reducer**  
TRW  
page 14



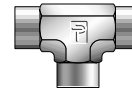
**Elbow**  
EW  
page 14



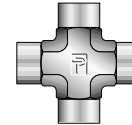
**45° Elbow**  
NW  
page 15



**Tee**  
JW  
page 15



**Cross**  
KW  
page 15



**Male Elbow**  
CW  
page 16



**Male Connector**  
FW  
page 16



**Female Connector**  
GW  
page 16



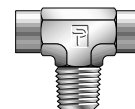
**Female Elbow**  
DW  
page 17



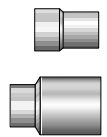
**Male Run Tee**  
RW  
page 17



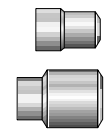
**Male Branch Tee**  
SW  
page 17



**Adapter**  
AW  
Page 18

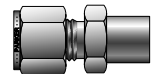


**Adapter**  
AW2  
page 19

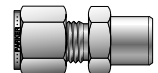


### Weld-lok® To Compression

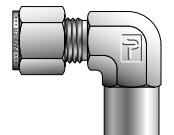
**Socket Weld Connector**  
ZHBW  
page 21



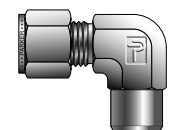
**Butt Weld Connector**  
ZHBW2  
page 22



**Socket Weld Elbow**  
ZEBW  
page 23



**Butt Weld Elbow**  
ZEBW2  
page 23



# Automatic Buttweld General Information

---

## Automatic Buttweld Purpose

Parker Buttweld fittings are designed for applications requiring the reliability of a welded tubing system. They were developed specifically for installation using automatic, orbital TIG (Tungsten/Inert Gas) welding equipment. These fittings offer the easiest, fastest and most reliable way to fabricate welded systems.

Automatic Buttweld fittings are available in 316, and 316L stainless steel in straight unions, tees, 90° elbows, and crosses. Automatic Buttweld ends are also available with male pipe and compression tube connections.

## Pressure

Pressure ratings will be governed by the tubing wall thickness selected for a particular application.

Working pressures are rated at room temperature based on a 4 to 1 design factor. Pressure ratings are calculated in accordance with ANSI Power Piping Code B31.1.

## Automatic Buttweld Principles of Operation

In an orbital welder, the electrode is contained and shielded within the head (see Figure 3). The head itself does not rotate; rather, the electrode rotates 360° within the head.

An orbital-type welder utilizes high-frequency current pulses, producing low-frequency arc pulses. These yield considerable arc penetration into the metal at low current values. As a result, arc-pressure variations are kept low and the resulting agitation of the weld puddle eliminates porosity and refines the grain structure at the weld area.

## To operate a TIG welding machine

1. Place the Automatic Buttweld fitting into the weld head, placing the locator rib in the corresponding locator groove.
2. Bottom the tubing (square cut, deburred) in the fitting end collar and close the second collet, which locks the tubing to the weld head. Engage the second collet.
3. Close the weld head. Press the "Start" button.

Note: Depending on the size and wall-thickness of the tubing, the welding machine parameters can be programmed to make one or more 360° passes. Once programmed, the machine will repeat the operation precisely, within very close tolerances and in areas too tight for manual welding.

---

## Backing Gas

Backing gas is an inert gas used to flood the interior of the fittings and tube system during welding. By reducing the interior oxygen level to as low as practicable, it also serves to control the combustion of contaminants that could affect weld quality.

When a backing gas is not used and nearly 100% weld penetration is achieved, blisters will tend to form on the internal tube wall. This will result in scale which may later break loose.

In most cases the backing gas will be argon or helium connected to the system through a control regulator. Flow rates,

## Automatic Centering of Electrode

Each Parker Automatic Buttweld fitting has an external locator rib (patented) situated a fixed distance from the end welding collar (see Figure 1). When the welder-head clamping collet is applied, the rib fits snugly within a corresponding annular groove in the collet.

As the electrode orbits, the collet follows the rib, maintaining precise positioning of the electrode, over the end collar (see Figure 2). Thus, electrode and welding positioning are always accurately aligned.

## End Weld Collar

On the O.D. of each Automatic Buttweld fitting end, there is an end collar. During welding, the electrode tip is positioned directly over this end collar. As the electrode orbits, a uniform bead on the butt-seam is achieved.

## Piloted Mating of Tube to Fitting

The end collar of the Automatic Buttweld fitting is counter bored. This serves as a pilot for the tube end, guiding it accurately into the fitting end.

This feature provides for accurate alignment and consistent welds every time.

## Compensation for Tube-Thickness Variations

The outside diameter of the end collar is designed to compensate for normal variations in the nominal O.D. of instrumentation tubing.

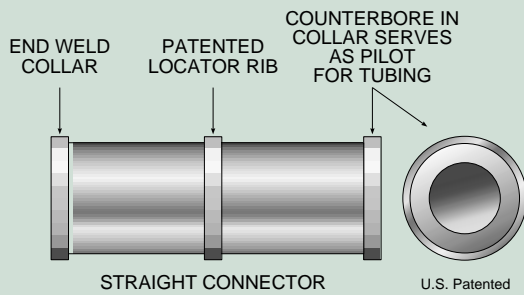
In addition, each fitting is machined for the specific wall thickness being specified.

These two features allow for the fitting bore and tube I.D. to be carefully matched. Thus, an ABW connection will allow for full flow, with no protrusions extending into the flow path. This will reduce a major cause of turbulence.

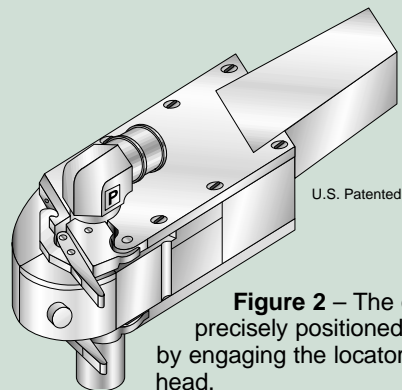
while small, should be high enough to purge the system. Welds should be made in downstream sequence from the gas connection.

Note that the entire system should be purged to insure that there are no openings that will allow air to be drawn into the system.

The use of backing gas, while often not mandatory, will give a better weld joint. This is because the welds are made and cooled under a shielded atmosphere, thus eliminating internal scaling or blistering.

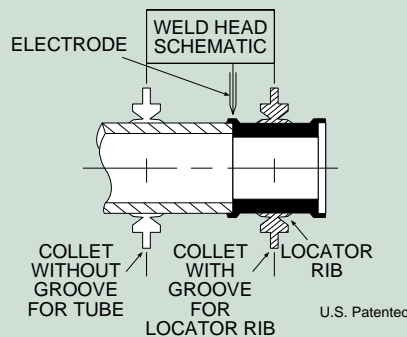


**Figure 1** – The Automatic Buttweld fitting has a locator rib positioned a fixed distance from the end weld collar.



**Figure 2** – The orbiting electrode is precisely positioned over the end collar by engaging the locator rib within the weld head.

**Note:** The weld head shown is for illustration only.



**Figure 3** – The orbital welder electrode is shielded within the stationary head and rotates 360° to produce uniform, accurate welds.

## Materials

**Automatic Buttweld Tube Fittings** are available in stainless steel (Type 316 and 316L - AOD/VAR and 316L VIM/VAR). Straight fittings are machined from cold finished bar stock and shaped bodies are machined from close grain forgings. The raw materials used for fittings fully conform to the chemical and mechanical requirements of one or more of the specifications listed in the table on page 6. For nuclear and other critical applications, Automatic Buttweld fittings are available with documented heat code traceability. (See page 2)

# How to Order Automatic Butt weld

## Nomenclature

Parker Automatic Butt weld Tube Fittings part numbers are constructed from symbols that identify the size and configuration of the fittings and material used.

## How To Order

Parker Butt weld components are ordered by part number as listed in this catalog.

**Example:** If your system requires an elbow fitting going from 1/4" tubing to 1/4" tubing, .035 wall thickness, you would order the following part:

**4-4 YEY-SS .035** (Automatic Butt weld)

**Fitting Size** – The first two numbers denote the fitting size which matches the tubing O.D.

**Machining Type** – First end ABW only (Y).

**Fitting Type** – Straight (H), Union tee (J), Union elbow (E).

**Machining Type** – Second end, ABW (Y), Male pipe (F), CPI™/A-LOK® end assembled (BZ/LZ).

**Wall Thickness** – Fittings must be specified to match the corresponding tube wall thickness. Standard wall thicknesses:  
 Size 4 and 6 – .035 wall thickness  
 Size 8 – .049 wall thickness  
 Other wall thicknesses available upon request.

**Material** – Stainless Steel - SS (316L)  
 AOD/VAR - SSR (316R)  
 VIM/VAR - SSV (316V)

**Size:** Tube and pipe thread sizes are designated by the number of sixteenths of an inch (1/4" tube = 4/16" = size 4), (3/8" tube = 6/16" = size 6), and (1/2" tube = 8/16" = size 8).

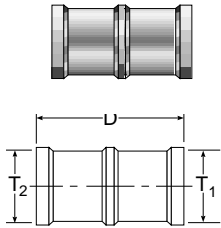
**Special fittings:** If a special fitting configuration is required, it is suggested that a sketch or drawing be submitted for review.

**Availability:** Only items listed in current price list are carried in stock. Customer Specials may be quoted through Parker ICD Division Customer Service.

TYPICAL RAW MATERIAL SPECIFICATIONS			
FITTING MATERIAL	BAR STOCK	FORGINGS	RECOMMENDED TUBING SPECIFICATIONS
Stainless Steel 316L	ASTM A-276 TYPE 316LSS ASME SA-479 TYPE 316L-SS	ASME SA-182 GRADE 316L	ASME SA-213 ASTM A-213 ASTM A-249 ASTM A-269 MIL T-8504 MIL T-8506
Stainless Steel 316L (AOD/VAR)			
Stainless Steel 316L (VIM/VAR)			

# Automatic Buttweld Fittings

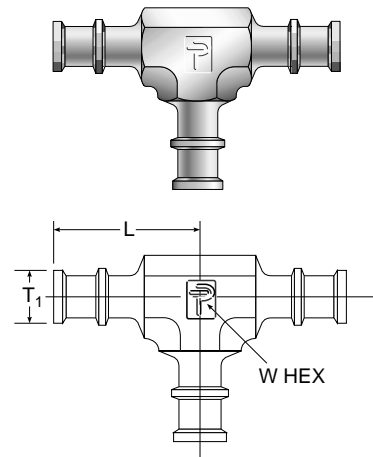
## Automatic Buttweld Union YHY



PART NO.	INCHES			
	D	T <sub>1</sub>	T <sub>2</sub>	*AUTO-BUTTWELD WALL SIZE
4-4 YHY	0.77	1/4	1/4	.035-.035
6-4 YHY	1.34	3/8	1/4	.035-.035
6-6 YHY	0.77	3/8	3/8	.035-.035
8-4 YHY	1.48	1/2	1/4	.049-.035
8-6 YHY	1.48	1/2	3/8	.049-.035
8-8 YHY	0.77	1/2	1/2	.049-.049
12-12 YHY	1.07	3/4	3/4	.065-.065
16-16 YHY	1.07	1	1	.095-.095

\*Other fittings and wall sizes available upon request

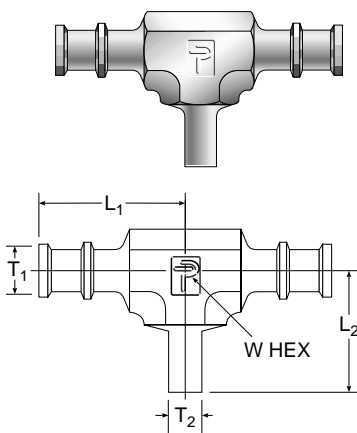
## Automatic Buttweld Union Tee YJY



PART NO.	INCHES			
	L	T <sub>1</sub>	*AUTO-BUTTWELD WALL SIZE	W HEX
4-4-4 YJY	1.06	1/4	.035	7/16
6-6-6 YJY	1.19	3/8	.035	9/16
8-8-8 YJY	1.44	1/2	.049	3/4
12-12-12 YJY	1.64	3/4	.065	1-1/16
16-16-16 YJY	1.81	1	.095	1-5/16

\*Other fittings and wall sizes available upon request

## Automatic Buttweld Manifold Branch Tee YJT3



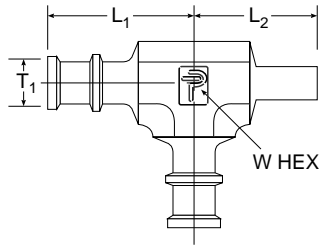
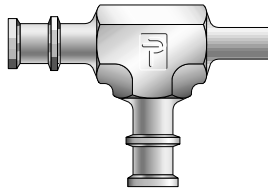
PART NO.	INCHES					
	L <sub>1</sub>	L <sub>2</sub>	T <sub>1</sub>	T <sub>2</sub>	*AUTO-BUTTWELD WALL SIZE	W HEX
4-4-4 YJT3	1.06	1.03	1/4	1/4	.035	7/16
6-6-4 YJT3	1.19	1.15	3/8	1/4	.035	9/16

\*Other fittings and wall sizes available upon request

Dimensions for reference only, subject to change.

# Automatic Butt weld Fittings

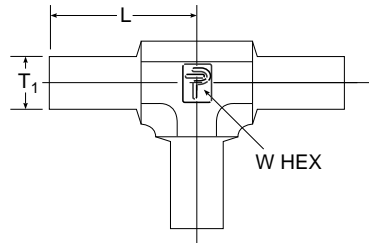
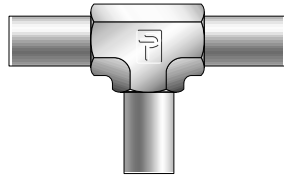
## Automatic Butt weld Manifold Run Tee YJT3Y



PART NO.	INCHES				
	L <sub>1</sub>	L <sub>2</sub>	T <sub>1</sub>	*AUTO-BUTTWELD WALL SIZE	W HEX
4-4-4 YJT3Y	1.06	1.03	1/4	.035	7/16

\*Other fittings and wall sizes available upon request

## Automatic Tube Butt weld Manifold Tee T3JT3



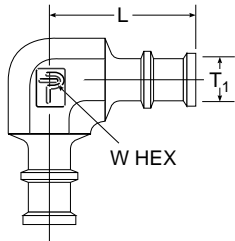
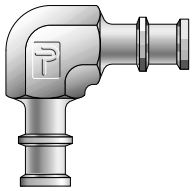
PART NO.	INCHES		
	L	T <sub>1</sub>	W HEX
4-4-4 T3JT3	1.03	1/4	7/16

Dimensions for reference only, subject to change.



# Automatic Butt weld Fittings

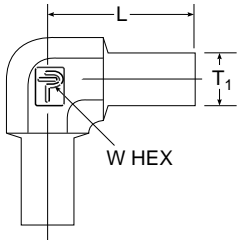
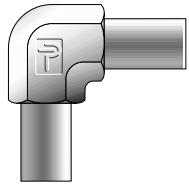
## Automatic Butt weld Union Elbow YEY



PART NO.	INCHES			
	L	T <sub>1</sub>	*AUTO-BUTTWELD WALL SIZE	W HEX
4-4 YEY	1.06	1/4	.035	7/16
6-6 YEY	1.19	3/8	.035	9/16
8-8 YEY	1.44	1/2	.049	3/4
12-12 YEY	1.64	3/4	.065	1-1/16
16-16 YEY	1.81	1	.095	1-5/16

\*Other fittings and wall sizes available upon request

## Automatic Tube Butt weld Manifold Elbow T3ET3

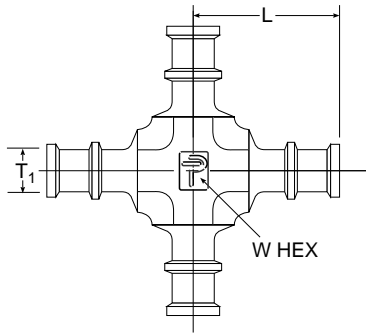
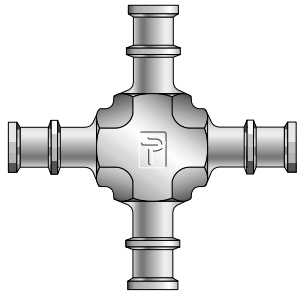


PART NO.	INCHES		
	L	T <sub>1</sub>	W HEX
4-4 T3ET3	1.03	1/4	7/16

Dimensions for reference only, subject to change.

# Automatic Buttweld Fittings

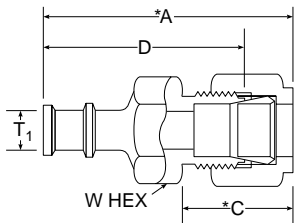
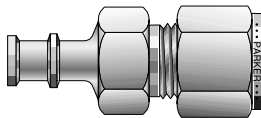
## Automatic Buttweld Cross YKY



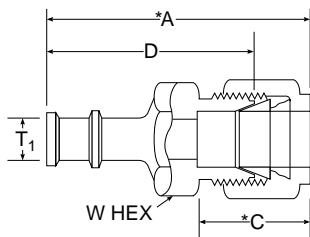
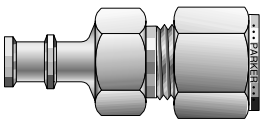
PART NO.	INCHES			
	L	T <sub>1</sub>	*AUTO-BUTTWELD WALL SIZE	W HEX
4 YKY	1.06	1/4	.035	7/16
6 YKY	1.19	3/8	.035	9/16
8 YKY	1.44	1/2	.049	3/4

\*Other fittings and wall sizes available upon request

## Automatic Buttweld to Tube Union



CPI™



A-LOK®

PART NO. (CPI™)	INCHES					
	D	T <sub>1</sub>	*A	*C	**AUTO-BUTTWELD WALL SIZE	W HEX
4-4 YHBZ	1.42	1/4	1.71	.70	.035	1/2
6-6 YHBZ	1.51	3/8	1.80	.78	.035	5/8
8-8 YHBZ	1.71	1/2	2.11	.91	.049	13/16

Silver plated nut and single ferrule are provided as shown.

\*Dimensions shown with nut finger tight

\*\*Other fittings and wall sizes available upon request.

PART NO. (A-LOK®)	INCHES					
	D	T <sub>1</sub>	*A	*C	**AUTO-BUTTWELD WALL SIZE	W HEX
4-4 YHLZ	1.42	1/4	1.71	.70	.035	1/2
6-6 YHLZ	1.51	3/8	1.80	.76	.035	5/8
8-8 YHLZ	1.71	1/2	2.11	.87	.049	13/16

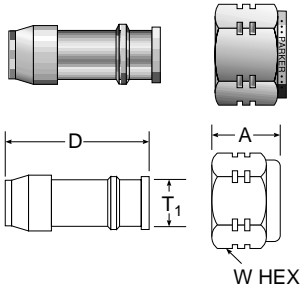
Silver plated nut and ferrules are provided as shown.

\*Dimensions shown with nut finger tight

\*\*Other fittings and wall sizes available upon request.

Dimensions for reference only, subject to change.

## Automatic Butt weld Adapter to Compression Port Connector ZPY

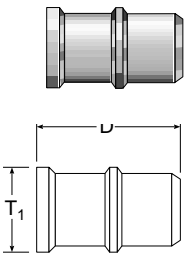


BODY PART NO.	INCHES		
	D	T <sub>1</sub>	*AUTO-BUTT WELD WALL SIZE
4-4 ZPY	1.12	1/4	.035
6-6 ZPY	1.09	3/8	.035
8-8 ZPY	1.52	1/2	.049
12-12 ZPY	1.50	3/4	.049
16-16 ZPY	1.71	1	.083

NUT PART NO.	INCHES	
	A	W HEX
4 BY	.50	9/16
6 BY	.56	11/16
8 BY	.69	7/8
12 BY	.69	1-1/8
16 BY	.81	1-1/2

\*Other fittings and wall sizes available upon request

## Automatic Butt weld Plug PNY



PART NO.	INCHES		
	D	T <sub>1</sub>	*AUTO-BUTT WELD WALL SIZE
4 PNY	0.72	1/4	.035
6 PNY	0.72	3/8	.035
8 PNY	0.72	1/2	.049
12 PNY	1.02	3/4	.065
16 PNY	1.02	1	.095

\*Other fittings and wall sizes available upon request

Dimensions for reference only, subject to change.

## Weld-lok® Socket Weld Fittings

The weld used in joining a tube to a socket weld tube fitting is like any other type of “tee” weld. The root (i.e., the point of intersection of the outside of the tube and annular end area of the fitting) must be included in the weld zone.

Careful welding procedures are normally followed to assure that this root area is included in the weld. If penetration is not achieved, the joint will have two built-in stress risers which may greatly reduce the strength of the weld. Upon application of an extreme load, these stress risers could result in cracks which could propagate out through the weld or tube depending upon the direction of the greatest load.

Often to achieve full root penetration in TIG welding of stainless steels, a fusion pass will be made first, followed by a final pass utilizing a filler rod to achieve the desired fillet size.

## Assembly

The codes applicable to the welding of socket weld fittings require that the tube be inserted into the socket until bottomed against the stop. The tube is then to be backed out approximately 1/16 of an inch and then welded.

If the tube is not backed out, but welded when against a flat bottom stop, the contraction of the weld fillet and fitting socket can combine to produce a static stress on the weld. During thermal transients, the fitting and the portion of the tube within the fitting may experience a differential rate of heating or cooling, again adding to the stress level in the weld.

## Tacking

If the weld joint is to be “tacked” before welding, it is recommended that the “Tack” weld build-up be held to a minimum.

Excessive build-up on the “tack” may cause an interrupted final bead and a stress riser or lack of complete fusion.

## Backing Gas

Backing gas is an inert (no active properties) gas used to flood the interior of the fittings and tube system during welding. It serves the same purpose internally as the shielding gas used in TIG or MIG welding. By reducing the interior oxygen level to as low as practicable, it also serves to control the combustion of contaminants that could affect weld quality.

When a backing gas is not used and nearly 100% weld penetration is achieved, blisters will tend to form on the internal tube wall. This will result in scale which may later break loose. Therefore, in 0.050 wall or thinner tube or where the wall thickness is such that the selected weld process may burn through, the use of a backing gas is required.

In most cases the backing gas will be argon or helium connected to the system through a control regulator. Flow rates, while small, should be high enough to purge the system. Welds should be made in downstream sequence from the gas connection.

Note that the entire system should be purged to insure that there are no openings that will allow air to be drawn into the system.

The use of backing gas, while often not mandatory, will give a better weld joint. This is because the effects of contaminate combustion by-products are eliminated and because the welds are made and cooled under a shielded atmosphere, thus eliminating internal scaling or blistering.

## Welding Methods

### Arc Polarity

When welding Weld-lok® fittings, best results will be obtained by the following arc polarities:

TIG – Direct Current, straight polarity  
MIG – Direct Current, reverse polarity  
STICK – Polarity dependent on rod used.

### 300 Series Stainless Steels

May be welded by the TIG, MIG, or stick arc-weld process.

TIG welding is recommended as being best for welding Weld-lok® systems because it allows better operator control of heat penetration and filler material deposition.

Stick arc welding is not recommended in many cases because of the likelihood of excessive burn-through and improper root penetration. In all cases where stick welding is used, it is recommended that backing gas be used.

MIG welding gives the same characteristics as stick electrode welding with faster deposition of the filler material. As this process runs “hotter” than the stick process, the use of a backing gas is mandatory. It should be noted that in welding the relatively small fitting sizes found in the Weld-lok® line, filler deposition rate economies are not a factor and therefore the MIG method is not commonly applied.

### C1018 Steel Fittings

May be welded by the TIG, MIG, stick and oxyacetylene methods. As scale formation remains a problem, the use of a backing gas is still recommended.

### Carbide Precipitation

When unstabilized stainless steels are heated to 800°–1500°F during welding, the chromium in the steel combines with the carbon to form chrome carbides which tend to form along the grain boundaries of the metal (carbide precipitation). This lowers the dissolved chromium content in these areas and thus lowers their corrosion resistance, making them vulnerable to intergranular corrosion. Carbide precipitation is reduced by holding the carbon content of the material to a very low value. This limits the amount of carbon available to combine with the chromium. The “L” series (extra low carbon) stainless steels are often used for this purpose, but their use reduces system design stress by approximately 15%. Parker Weld-lok® fittings are made from a select 316 series with carbon content in the low range of 0.04 to 0.07 percent. This results in a welded fitting with good corrosion resistance and a high strength factor.

All Parker Weld-lok® fittings in stainless steel are supplied in the solution-treated condition, capable of passing ASTM-A-262 Tests for Detecting Susceptibility to Intergranular Corrosion.

## How To Order

Parker Weld-lok® components are ordered by part number as listed in this catalog.

**Example:** If your system requires a 90° elbow fitting going from 1/4" tubing to 1/4" tubing, you would order the following part:

**4-4 EW-SS**

Fitting Size – The first two numbers denote the fitting size which matches the tubing O.D.

Material – Stainless Steel - SS (316L)

Welded Fitting Type – Straight (H), Union tee (J), Union elbow (E).

Machining Type – Weld-lok® (W)

Size: Tube and pipe thread sizes are designated by the number of sixteenths of an inch (1/4" tube = 4/16" = size 4), (3/8" tube = 6/16" = 6), and (1/2" tube = 8/16" = size 8).

*Special fittings:* If a special fitting configuration is required, it is suggested that a sketch or drawing be submitted for review.

*Availability:* Only items listed in current price list (4280) are carried in stock. Customer Specials may be quoted through the Parker ICD Quick Response Department.

TYPICAL RAW MATERIAL SPECIFICATIONS			
FITTING MATERIAL	BAR STOCK	FORGINGS	RECOMMENDED TUBING SPECIFICATIONS
Stainless Steel 316L	ASTM A-276 TYPE 316LSS ASME SA-479 TYPE 316L-SS	ASME SA-182 GRADE 316L	ASME SA-213 ASTM A-213 ASTM A-249 ASTM A-269 MIL T-8504 MIL T-8506
Stainless Steel 304	TBA	TBA	

## Where To Order

Parker Weld-lok® components are ordered with the Instrumentation Connectors Division.  
 P.O. Box 400004-1504  
 Huntsville, AL 35815-1504  
 Phone: 256-881-2040

## Design Specifications

The Weld-lok® fitting has been designed and tested in accordance with ANSI B16.11, which covers "Forged Steel Fittings Socket Welded and Threaded." Our design parallels the Schedule 80, 3000-pound fitting pressure class, and is compatible with O.D. tube wall thickness meeting the related (3000-psi pipe class) pressure requirements. Strong, full section forgings are used for all "shape" fittings.

## User Specification Requirements

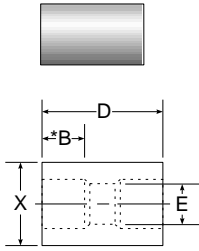
The 316 stainless steel Weld-lok® fittings fully conforms to the applicable specifications covered in:

- ANSI B31.1 "Power Piping"
  - ANSI B31.7 "Nuclear Power Piping"
  - Section III, "Nuclear Power Plant Component," ASME Boiler and Pressure Vessel Code
- Customer Specials may be quoted through the Parker Quick Response Department.

# Weld-lok® Socket Weld Tube Fittings

## Union

HW • tube socket end – both ports

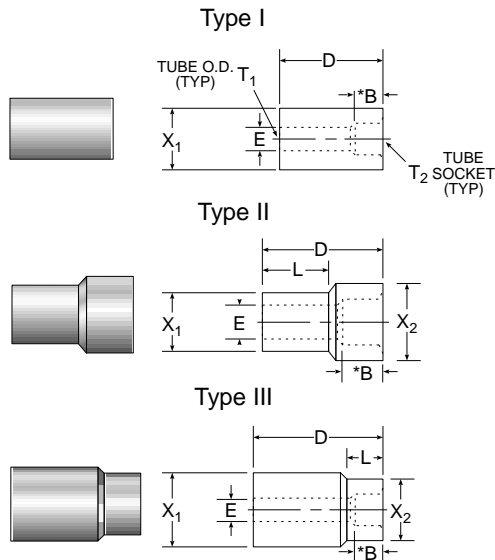


PART NO.	TUBE O.D.	TUBE O.D.	E SMALL BORE	*B	D	J	X DIA.	WORK. PRES.
2 HW	1/8	1/8	.09	.156	.69		.375	10,200
3 HW	3/16	3/16	.14	.203	.78		.438	9,600
4-3 HW	1/4	3/16	.14	.25-.20	.85	.44-.39	.50-.44	9,600
4 HW	1/4	1/4	.19	.250	.88		.500	9,600
5 HW	5/16	5/16	.25	.313	1.00		.594	9,900
6-4 HW	3/8	1/4	.19	.34-.25	1.00	.53-.44	.63-.50	8,100
6 HW	3/8	3/8	.31	.344	1.06		.625	8,100
8-4 HW	1/2	1/4	.19	.41-.25	1.11	.59-.44	.78-.50	7,300
8-6 HW	1/2	3/8	.31	.41-.34	1.17	.59-.53	.78-.63	7,300
8 HW	1/2	1/2	.44	.406	1.19		.781	7,300
10-6 HW	5/8	3/8	.31	.47-.34	1.28	.66-.53	.94-.63	6,600
10 HW	5/8	5/8	.50	.469	1.31		.938	6,600
12-4 HW	3/4	1/4	.19	.50-.25	1.30	.69-.44	1.09-.50	6,000
12-8 HW	3/4	1/2	.44	.50-.41	1.37	.69-.59	1.09-.78	6,000
12-10 HW	3/4	5/8	.50	.50-.47	1.39	.69-.66	1.09-.94	6,000
12 HW	3/4	3/4	.66	.500	1.38		1.094	6,000
14 HW	7/8	7/8	.78	.500	1.38		1.312	5,700
16-8 HW	1	1/2	.44	.56-.41	1.53	.75-.59	1.44-.78	4,900
16-12 HW	1	3/4	.66	.56-.50	1.54	.75-.69	1.44-1.09	4,900
16 HW	1	1	.91	.563	1.50		1.44	4,900
20-12 HW	1-1/4	3/4	.66	.63-.50	1.69	.81-.69	1.75-1.09	4,600
20-16 HW	1-1/4	1	.91	.63-.56	1.65	.81-.75	1.75-1.44	4,600
20 HW	1-1/4	1-1/4	1.06	.625	1.625		1.750	4,600
24-8 HW	1-1/2	1/2	.44	.67-.41	1.80	.86-.59	2.0-.78	3,700
24-16 HW	1-1/2	1	.91	.67-.56	1.77	.86-.75	2.0-1.44	3,700
24-20 HW	1-1/2	1-1/4	1.06	.67-.63	1.74	.86-.81	2.0-1.75	3,700
24 HW	1-1/2	1-1/2	1.31	.670	1.84		2.0	3,700
32-16 HW	2	1	.91	.78-.56	2.06	.97-.75	2.62-1.44	3,300
32 HW	2	2	1.81	.781	2.13		2.625	3,300

\*Socket Depth

## Tube Reducer

TRW • tube socket reducer



PART NO.	T <sub>1</sub> SIZE	T <sub>2</sub> TUBE SOCK.	TYPE	D	X <sub>1</sub> DIA.	X <sub>2</sub> DIA.	L	E SMALL BORE	*B	WORK. PRES.
6-4 TRW	3/8	1/4	II	.94	.375	.500	.47	.19	.250	9,600
8-4 TRW	1/2	1/4	I	.88	.500	.50	-	.19	.250	9,600
8-6 TRW	1/2	3/8	II	1.13	.500	.63	.56	.31	.344	7,800
10-4 TRW	5/8	1/4	III	1.22	.623	.50	.44	.19	.250	9,600
10-6 TRW	5/8	3/8	I	1.03	.623	.62	-	.31	.344	8,100
10-8 TRW	5/8	1/2	II	1.26	.623	.78	.63	.41	.406	6,100
12-4 TRW	3/4	1/4	III	1.32	.750	.50	.44	.19	.250	9,600
12-6 TRW	3/4	3/8	III	1.38	.750	.63	.53	.31	.344	8,100
12-8 TRW	3/4	1/2	II	1.29	.750	.78	.69	.44	.406	7,300
12-10 TRW	3/4	5/8	II	1.40	.750	.94	.69	.50	.469	6,600
16-4 TRW	1	1/4	III	1.44	1.000	.50	.44	.19	.250	9,600
16-6 TRW	1	3/8	III	1.50	1.000	.63	.53	.31	.344	8,100
16-8 TRW	1	1/2	III	1.51	1.000	.78	.59	.44	.406	7,300
16-10 TRW	1	5/8	III	1.52	1.000	.94	.66	.50	.469	6,600
16-12 TRW	1	3/4	II	1.47	1.000	1.09	.75	.66	.500	6,000
20-4 TRW	1-1/4	1/4	III	1.65	1.250	.50	.44	.19	.250	9,600
20-6 TRW	1-1/4	3/8	III	1.68	1.250	.63	.53	.31	.344	8,100
20-8 TRW	1-1/4	1/2	III	1.73	1.250	.78	.59	.44	.406	7,300
20-12 TRW	1-1/4	3/4	III	1.73	1.250	1.09	.69	.66	.500	6,000
20-16 TRW	1-1/4	1	II	1.68	1.250	1.44	.88	.91	.563	4,900
24-12 TRW	1-1/2	3/4	III	1.85	1.500	1.09	.69	.66	.500	6,000
24-16 TRW	1-1/2	1	III	1.81	1.50	1.34	.75	.91	.563	4,900
24-20 TRW	1-1/2	1-1/4	II	1.70	1.500	1.75	.81	1.06	.625	4,600

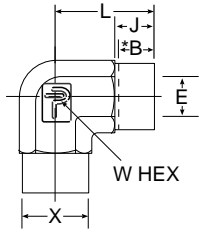
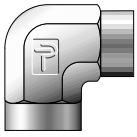
\*Socket Depth

**NOTE:** Other drop sizes available upon request.  
Dimensions for reference only, subject to change.

# Weld-lok® Socket Weld Tube Fittings

## Elbow

EW • tube socket end – both ports

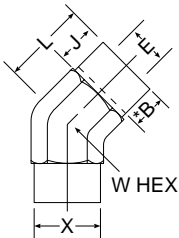


PART NO.	TUBE O.D. <sub>1</sub>	TUBE O.D. <sub>2</sub>	E SMALL BORE	*B	L	J	W HEX	X DIA.	WORK. PRES.
2 EW	1/8	1/8	.09	.156	.70	.34	1/2	.375	10,200
3 EW	3/16	3/16	.14	.203	.75	.39	1/2	.438	9,600
4 EW	1/4	1/4	.19	.250	.84	.44	9/16	.500	9,600
5 EW	5/16	5/16	.25	.313	.90	.50	9/16	.594	9,900
6-4 EW	3/8	1/4	.19	.344	1.08-.98	.53-.44	13/16	.63-.50	8,100
6 EW	3/8	3/8	.31	.344	1.08	.53	13/16	.625	8,100
8-4 EW	1/2	1/4	.19	.406	1.14-.98	.59-.44	7/8	.78-.50	7,300
8-6 EW	1/2	3/8	.31	.406	1.14-1.08	.59-.53	7/8	.78-.63	7,300
8 EW	1/2	1/2	.44	.406	1.14	.59	7/8	.781	7,300
10 EW	5/8	5/8	.50	.469	1.36	.66	1-1/16	.938	6,600
12 EW	3/4	3/4	.66	.500	1.39	.69	1-1/16	1.094	6,000
14 EW	7/8	7/8	.78	.500	1.58	.69	1-3/8	1.312	5,700
16 EW	1	1	.91	.563	1.84	.75	1-5/8	1.438	4,400
20 EW	1-1/4	1-1/4	1.06	.625	2.10	.81	1-7/8	1.750	4,600
24 EW	1-1/2	1-1/2	1.31	.670	2.54	.86	1-1/2	2.000	3,700
32 EW	2	2	1.81	.781	2.78	.97	2-13/16	2.625	3,300

\*Socket Depth

## 45° Elbow

NW • tube socket – both ends

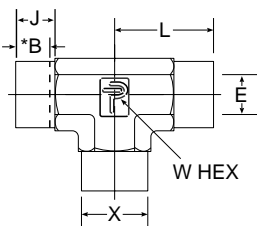
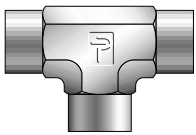


PART PART NO.	TUBE O.D.	TUBE O.D.	E SMALL BORE	L	X DIA.	W HEX	*B	J	WORK. PRES.
2 NW	1/8	1/8	.09	.53	.375	7/16	.156	.34	10,200
3 NW	3/16	3/16	.14	.73	.438	9/16	.203	.39	9,600
4 NW	1/4	1/4	.19	.84	.500	9/16	.250	.44	9,600
5 NW	5/16	5/16	.25	.86	.594	9/16	.313	.50	9,900
6 NW	3/8	3/8	.31	1.078	.625	7/8	.344	.53	8,100
8 NW	1/2	1/2	.44	1.14	.781	7/8	.406	.59	7,300
10 NW	5/8	5/8	.50	1.36	.938	1-1/16	.469	.66	6,600
12 NW	3/4	3/4	.66	1.34	1.094	1-1/16	.500	.69	6,000
16 NW	1	1	.91	1.63	1.438	1-5/8	.563	.75	4,400
20 NW	1-1/4	1-1/4	1.06	1.63	1.75	1-7/8	.625	.81	4,600
24 NW	1-1/2	1-1/2	1.31	1.67	2.00	2-1/2	.670	.86	3,700
32 NW	2	2	1.81	1.67	2.63	2-1/2	.781	.97	3,300

\*Socket Depth

## Tee

JW • tube socket end – all 3 ports



TUBE PART NO.	TUBE O.D. <sub>1</sub>	TUBE O.D. <sub>2</sub>	TUBE O.D. <sub>3</sub>	E SMALL BORE	*B	J	L	W HEX	X DIA.	WORK. PRES.
2 JW	1/8	1/8	1/8	.09	.156	.34	.70	1/2	.375	10,200
3 JW	3/16	3/16	3/16	.14	.203	.39	.75	1/2	.438	9,600
4 JW	1/4	1/4	1/4	.19	.250	.44	.84	9/16	.500	9,600
5 JW	5/16	5/16	5/16	.25	.313	.50	.90	9/16	.594	9,900
6-6-4 JW	3/8	3/8	1/4	.19	.34-.25	.53-.44	1.08-.99	13/16	.63-.50	8,100
6 JW	3/8	3/8	3/8	.31	.344	.53	1.08	13/16	.625	8,100
8-4-4 JW	1/2	1/4	1/4	.19	.41-.25	.59-.44	1.14-.98	7/8	.78-.50	7,300
8-6-6 JW	1/2	3/8	3/8	.31	.41-.34	.59-.53	1.14-1.08	7/8	.78-.63	7,300
8-8-4 JW	1/2	1/2	1/4	.19	.41-.25	.59-.44	1.14-.98	7/8	.78-.50	7,300
8-8-6 JW	1/2	1/2	3/8	.31	.41-.34	.59-.53	1.14-1.08	7/8	.78-.63	7,300
8 JW	1/2	1/2	1/2	.44	.406	.59	1.14	7/8	.781	7,300
10 JW	5/8	5/8	5/8	.50	.469	.66	1.36	1-1/16	.938	6,600
12-8-12 JW	3/4	1/2	3/4	.44	.50-.41	.69-.59	1.39-1.29	1-1/16	1.09-.78	6,000
12 JW	3/4	3/4	3/4	.66	.500	.69	1.39	1-1/16	1.094	6,000
14 JW	7/8	7/8	7/8	.78	.500	.69	1.58	1-3/8	1.312	5,700
16-8-16 JW	1	1.2	1	.44	.56-.41	.75-.59	1.84-1.68	1-5/8	1.44-.78	4,400
16-12-16 JW	1	3/4	1	.66	.56-.50	.75-.69	1.84-1.77	1-5/8	1.44-1.09	4,400
16 JW	1	1	1	.91	.563	.750	1.84	1-5/8	1.44	4,400
20-16-20 JW	1-1/4	1	1-1/4	.91	.63-.56	.81-.75	2.10-2.04	1-7/8	1.75-1.44	4,600
20 JW	1-1/4	1-1/4	1-1/4	1.06	.625	.812	2.102	1-7/8	1.750	4,600
24-16-24 JW	1-1/2	1	1-1/2	.91	.67-.56	.86-.75	2.54-2.44	2-1/2	2.00-1.44	3,700
24 JW	1-1/2	1-1/2	1-1/2	1.31	.670	.857	2.54	2-1/2	2.000	3,700
32 JW	2	2	2	1.81	.781	.968	2.78	2-13/16	2.625	3,300

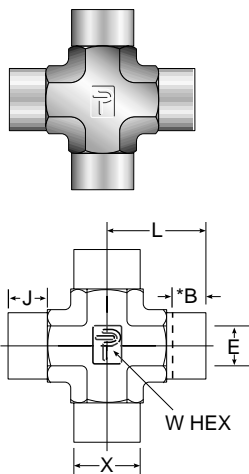
\*Socket Depth

**NOTE:** Other drop sizes available upon request.  
Dimensions for reference only, subject to change.

# Weld-lok® Socket Weld Tube Fittings

## Cross

KW • tube socket end – all 4 ports

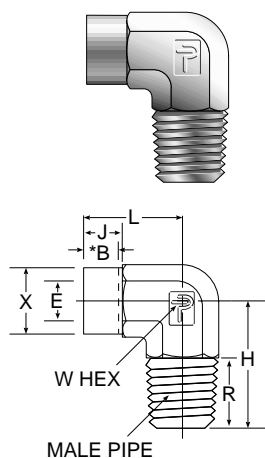


PART NO.	TUBE O.D.	E SMALL BORE	*B	J	L	W HEX	X DIA.	WORK. PRES.
2 KW	1/8	.09	1.56	.34	.70	1/2	.375	10,200
3 KW	3/16	.14	.203	.39	.75	1/2	.438	9,600
4 KW	1/4	.19	.250	.44	.84	9/16	.500	9,600
5 KW	5/16	.25	.313	.50	.90	9/16	.594	9,900
6 KW	3/8	.31	.344	.53	1.08	13/16	.625	8,100
8 KW	1/2	.44	.406	.59	1.14	13/16	.781	7,300
10 KW	5/8	.50	.469	.66	1.36	1-1/16	.938	6,600
12 KW	3/4	.66	.500	.69	1.39	1-1/16	1.094	6,000
16 KW	1	.91	.563	.75	1.84	1-5/8	1.438	4,400
20 KW	1-1/4	1.06	.625	.81	2.10	1-7/8	1.750	4,600
24 KW	1-1/2	1.31	.670	.86	2.54	2-9/16	2.000	3,700
32 KW	2	1.81	.781	.97	2.78	2-9/16	2.625	3,300

\*Socket Depth

## Male Elbow

CW • tube socket end – male pipe end



PART NO.	TUBE O.D.	MALE PIPE	E SMALL BORE	*B	H	J	L	R	W HEX	X DIA.	WORK. PRES.
2 CW	1/8	1/8	.09	.156	.74	.34	.70	.38	1/2	.375	9,100
2-4 CW	1/8	1/4	.09	.156	.93	.34	.70	.56	1/2	.375	7,500
3 CW	3/16	1/8	.14	.203	.74	.39	.75	.38	1/2	.438	9,100
4 CW	1/4	1/8	.19	.250	.79	.44	.84	.38	9/16	.500	9,100
4-4 CW	1/4	1/4	.19	.250	.97	.44	.84	.56	9/16	.500	7,500
5 CW	5/16	1/8	.25	.313	.79	.50	.90	.38	9/16	.594	9,100
6 CW	3/8	1/4	.31	.344	1.12	.53	1.08	.56	13/16	.625	7,500
6-6 CW	3/8	3/8	.31	.344	1.12	.53	1.08	.56	13/16	.625	7,200
6-8 CW	3/8	1/2	.31	.344	1.31	.53	1.08	.75	13/16	.625	5,800
8-4 CW	1/2	1/4	.44	.406	1.12	.59	1.14	.56	7/8	.78	7,300
8 CW	1/2	3/8	.44	.406	1.12	.59	1.14	.56	7/8	.78	7,200
8-8 CW	1/2	1/2	.44	.406	1.31	.59	1.14	.75	13/16	.78	5,800
10 CW	5/8	1/2	.50	.469	1.46	.66	1.36	.75	1-1/16	.94	5,800
12-4 CW	3/4	1/4	.66	.500	1.27	.69	1.39	.56	1-1/16	1.09	6,000
12-8 CW	3/4	1/2	.66	.500	1.46	.69	1.39	.75	1-1/16	1.09	5,800
12 CW	3/4	3/4	.66	.500	1.46	.69	1.39	.75	1-1/16	1.09	6,000
16-12 CW	1	3/4	.72	.563	1.84	.75	1.84	.75	1-5/8	1.44	4,900
16 CW	1	1	.91	.563	2.03	.75	1.84	.94	1-5/8	1.44	4,400
20 CW	1-1/4	1-1/4	1.06	.625	2.27	.81	2.10	.97	1-7/8	1.750	3,500
24 CW	1-1/2	1-1/2	1.31	.670	2.69	.86	2.54	1.00	2-1/2	2.000	2,900

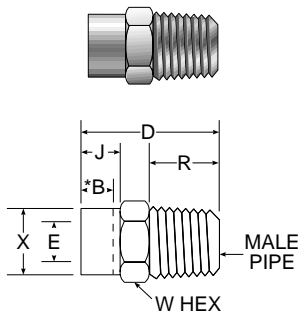
\*Socket Depth

**NOTE:** Other drop sizes available upon request.  
Dimensions for reference only, subject to change.



## Male Connector

FW • tube socket end – male pipe end

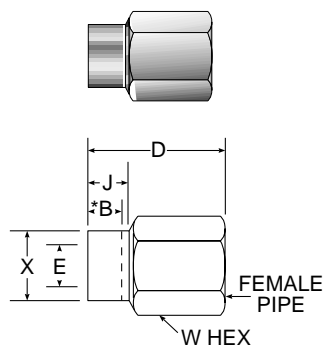


PART NO.	TUBE O.D.	MALE SOCK.	E SMALL BORE	*B	D	J	R	W HEX	X DIA.	WORK. PRES.
2 FW	1/8	1/8	.09	.156	.94	.34	.38	7/16	.375	9,100
2-4 FW	1/8	1/4	.09	.156	1.14	.34	.56	9/16	.375	7,500
3 FW	3/16	1/8	.14	.203	.94	.39	.38	1/2	.438	9,100
3-4 FW	3/16	1/4	.14	.203	1.19	.39	.56	9/16	.438	7,500
4 FW	1/4	1/8	.19	.250	1.05	.44	.38	9/16	.500	9,100
4-4 FW	1/4	1/4	.19	.250	1.23	.44	.56	9/16	.500	7,500
4-8 FW	1/4	1/2	.19	.250	1.50	.44	.75	7/8	.500	6,600
5 FW	5/16	1/8	.25	.313	1.13	.50	.38	5/8	.594	9,100
6-2 FW	3/8	1/8	.19	.344	1.16	.53	.38	11/16	.625	8,100
6 FW	3/8	1/4	.28	.344	1.34	.53	.56	11/16	.625	7,500
6-6 FW	3/8	3/8	.31	.344	1.34	.53	.56	11/16	.625	7,200
6-8 FW	3/8	1/2	.31	.344	1.59	.53	.75	7/8	.625	6,600
6-12 FW	3/8	3/4	.31	.344	1.66	.53	.75	1-1/16	.625	6,400
8-2 FW	1/2	1/8	.19	.406	1.25	.59	.38	13/16	.781	7,300
8-4 FW	1/2	1/4	.28	.406	1.44	.59	.56	13/16	.781	7,300
8 FW	1/2	3/8	.41	.406	1.44	.59	.56	13/16	.781	7,200
8-8 FW	1/2	1/2	.44	.406	1.66	.59	.75	7/8	.781	6,600
8-12 FW	1/2	3/4	.44	.406	1.72	.59	.75	1-1/16	.781	6,400
10-4 FW	5/8	1/4	.28	.469	1.56	.66	.56	1	.938	6,600
10-6 FW	5/8	3/8	.41	.469	1.56	.66	.56	1	.938	6,600
10 FW	5/8	1/2	.50	.469	1.75	.66	.75	1	.938	6,600
10-12 FW	5/8	3/4	.50	.469	1.78	.66	.75	1-1/16	.938	6,400
12-8 FW	3/4	1/2	.50	.500	1.81	.69	.75	1-1/8	1.094	6,000
12 FW	3/4	3/4	.66	.500	1.81	.69	.75	1-1/8	1.094	6,000
12-16 FW	3/4	1	.66	.500	2.09	.69	.94	1-3/8	1.094	4,600
14 FW	7/8	3/4	.66	.500	1.91	.69	.75	1-3/8	1.312	5,700
16-8 FW	1	1/2	.50	.563	2.02	.75	.75	1-5/8	1.438	4,900
16-12 FW	1	3/4	.72	.563	2.02	.75	.75	1-5/8	1.438	4,900
16 FW	1	1	.91	.563	2.20	.75	.94	1-5/8	1.438	4,600
20-12 FW	1-1/4	3/4	.72	.625	2.14	.81	.75	1-7/8	1.750	4,600
20-16 FW	1-1/4	1	.94	.625	2.33	.81	.94	1-7/8	1.750	4,600
20 FW	1-1/4	1-1/4	1.06	.625	2.36	.81	.97	1-7/8	1.750	3,500
20-24 FW	1-1/4	1-1/2	1.06	.625	2.42	.81	1.00	2	1.750	2,900
24-20 FW	1-1/2	1-1/4	1.25	.670	2.49	.86	.97	2-1/8	2.000	3,500
24 FW	1-1/2	1-1/2	1.31	.670	2.52	.86	1.00	2-1/8	2.000	2,900
32 FW	2	2	1.81	.781	2.97	.97	1.03	2-3/4	2.625	2,600

\*Socket Depth

## Female Connector

GW • tube socket end – female pipe end



PART PART NO.	TUBE O.D.	FEMALE PIPE	E SMALL BORE	*B	D	J	W HEX	X DIA.	WORK. PRES.
2 GW	1/8	1/8	.09	.156	.95	.34	9/16	.375	6,400
3 GW	3/16	1/8	.14	.203	.98	.39	9/16	.438	6,400
4 GW	1/4	1/8	.19	.250	1.01	.44	9/16	.500	6,400
4-4 GW	1/4	1/4	.19	.250	1.26	.44	3/4	.500	6,600
4-12 GW	1/4	3/4	.19	.250	1.80	.44	1-1/4	.500	4,300
5 GW	5/16	1/8	.25	.313	1.07	.50	5/8	.594	6,400
6-2 GW	3/8	1/8	.31	.344	1.11	.53	11/16	.625	6,400
6 GW	3/8	1/4	.31	.344	1.32	.53	3/4	.625	6,600
6-6 GW	3/8	3/8	.31	.344	1.42	.53	15/16	.625	5,300
6-8 GW	3/8	1/2	.31	.344	1.67	.53	1-1/16	.625	5,200
6-12 GW	3/8	3/4	.31	.344	1.86	.53	1-1/4	.625	4,300
6-16 GW	3/8	1	.31	.344	2.30	.53	1-5/8	.625	4,500
8-2 GW	1/2	1/8	.34	.406	1.17	.59	13/16	.781	6,400
8-4 GW	1/2	1/4	.44	.406	1.36	.59	13/16	.781	6,600
8 GW	1/2	3/8	.44	.406	1.44	.59	7/8	.781	5,300
8-8 GW	1/2	1/2	.44	.406	1.69	.59	1-1/16	.781	5,200
10-6 GW	5/8	3/8	.50	.469	1.52	.66	1-1/16	.938	5,300
10 GW	5/8	1/2	.50	.469	1.71	.66	1-1/16	.938	5,200
10-16 GW	5/8	1	.50	.469	2.33	.66	1-5/8	.938	4,500
12-8 GW	3/4	1/2	.66	.500	1.72	.69	1-1/8	1.094	5,200
12 GW	3/4	3/4	.66	.500	1.88	.69	1-1/4	1.094	4,300
14 GW	7/8	3/4	.78	.500	1.86	.69	1-3/8	1.312	4,300
16-8 GW	1	1/2	.71	.563	1.85	.75	1-5/8	1.438	4,900
16-12 GW	1	3/4	.91	.563	1.97	.75	1-5/8	1.438	4,300
16 GW	1	1	.91	.563	2.28	.75	1-5/8	1.438	4,500
20 GW	1-1/4	1-1/4	1.06	.625	2.39	.81	2	1.750	3,500

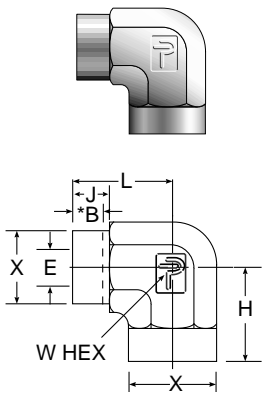
\*Socket Depth

**NOTE:** Other drop sizes available upon request.  
Dimensions for reference only, subject to change.

# Weld-lok® Socket Weld Tube Fittings

## Female Elbow

DW • tube socket end – female pipe end

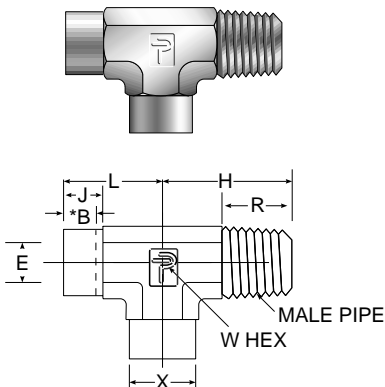


PART NO.	TUBE O.D.	FEMALE PIPE	E SMALL BORE	*B	H	J	L	W HEX	X DIA.	WORK. PRES.
2 DW	1/8	1/8	.09	.156	.75	.34	.70	1/2	.375	5,500
3 DW	3/16	1/8	.14	.203	.75	.39	.75	1/2	.438	5,500
4 DW	1/4	1/8	.19	.250	.75	.44	.84	9/16	.500	5,500
4-4 DW	1/4	1/4	.19	.250	.88	.44	.91	11/16	.500	5,600
5 DW	5/16	1/8	.25	.313	.75	.50	.90	9/16	.594	5,500
6 DW	3/8	1/4	.31	.344	.88	.53	1.00	11/16	.625	5,600
6-6 DW	3/8	3/8	.31	.344	.88	.53	1.08	13/16	.625	5,000
6-8 DW	3/8	1/2	.31	.344	1.12	.53	1.19	1	.625	4,500
8-4 DW	1/2	1/4	.44	.406	.88	.59	1.14	7/8	.781	5,600
8 DW	1/2	3/8	.44	.406	.88	.59	1.14	13/16	.781	5,000
8-8 DW	1/2	1/2	.44	.406	1.12	.59	1.29	1-1/16	.781	4,500
10 DW	5/8	1/2	.50	.469	1.12	.66	1.36	1-1/16	.938	4,500
12-4 DW	3/4	1/4	.66	.500	1.12	.69	1.39	1-1/16	1.094	5,600
12 DW	3/4	3/4	.66	.500	1.25	.69	1.58	1-5/16	1.094	3,500
14-12 DW	7/8	3/4	.78	.500	1.25	.69	1.58	1-3/8	1.312	3,500
16-6 DW	1	3/8	.91	.563	1.75	.75	1.84	1-5/8	1.438	4,900
16 DW	1	1	.91	.563	1.50	.75	1.84	1-5/8	1.438	3,900
20 DW	1-1/4	1-1/4	1.06	.625	1.88	.81	2.10	1-7/8	1.750	3,100
24-16 DW	1-1/2	1	1.31	.670	2.08	.86	2.54	2-1/2	2.000	3,700
24 DW	1-1/2	1-1/2	1.31	.670	2.13	.86	2.54	2-1/2	2.000	2,500

\*Socket Depth

## Male Run Tee

RW • socket weld – male run tee

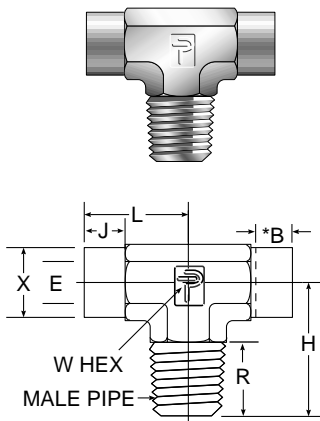


PART NO.	TUBE O.D.	MALE PIPE	E SMALL BORE	L	H	X DIA.	W HEX	*B	J	R	WORK. PRES.
2 RW	1/8	1/8	.09	.70	.74	.375	1/2	.156	.34	.38	9,100
3 RW	3/16	1/8	.14	.75	.75	.438	1/2	.203	.39	.38	9,100
4 RW	1/4	1/8	.19	.84	.79	.500	9/16	.250	.44	.38	9,100
5 RW	5/16	1/8	.19	.90	.79	.594	9/16	.313	.50	.38	9,100
6 RW	3/8	1/4	.28	1.08	1.12	.625	13/16	.344	.53	.56	7,500
8 RW	1/2	3/8	.41	1.14	1.12	.781	13/16	.406	.59	.56	7,200
10 RW	5/8	1/2	.50	1.36	1.46	.938	1-1/16	.469	.66	.75	5,800
12 RW	3/4	3/4	.656	1.39	1.46	1.094	1-1/16	.500	.69	.75	6,000
14 RW	7/8	3/4	.719	1.58	1.65	1.312	1-3/8	.500	.69	.75	5,700
16 RW	1	1	.906	1.84	2.03	1.438	1-5/16	.563	.75	.94	4,400
20 RW	1-1/4	1-1/4	1.063	2.10	2.27	1.750	1-7/8	.625	.81	.97	3,500
24 RW	1-1/2	1-1/2	1.313	2.54	2.70	2.000	2-1/2	.670	.86	1.00	2,900
32 RW	2	2	1.813	2.78	2.85	2.625	2-13/16	.781	.97	1.03	2,600

\*Socket Depth

## Male Branch Tee

SW • socket weld – male outlet tee



PART NO.	TUBE O.D.	MALE PIPE	E SMALL BORE	L	H	X DIA.	W HEX	*B	J	R	WORK. PRES.
2 SW	1/8	1/8	.09	.70	.74	.375	1/2	.156	.34	.38	9,100
3 SW	3/16	1/8	.14	.75	.75	.438	1/2	.203	.39	.38	9,100
4 SW	1/4	1/8	.19	.84	.79	.500	9/16	.250	.44	.38	9,100
5 SW	5/16	1/8	.19	.90	.79	.594	9/16	.313	.50	.38	9,100
6 SW	3/8	1/4	.28	1.08	1.12	.625	13/16	.344	.53	.56	7,500
8 SW	1/2	3/8	.41	1.14	1.12	.781	13/16	.406	.59	.56	7,200
10 SW	5/8	1/2	.50	1.36	1.47	.938	1-1/16	.469	.66	.75	5,800
12 SW	3/4	3/4	.66	1.39	1.46	1.094	1-1/16	.500	.69	.75	6,000
14 SW	7/8	3/4	.72	1.58	1.65	1.312	1-3/8	.500	.69	.75	5,700
16 SW	1	1	.91	1.84	2.03	1.438	1-5/16	.563	.75	.94	4,400
20 SW	1-1/4	1-1/4	1.06	2.10	2.27	1.750	1-7/8	.625	.81	.97	3,500
24 SW	1-1/2	1-1/2	1.31	2.54	2.70	2.000	2-1/2	.670	.86	1.00	2,900
32 SW	2	2	1.81	2.78	2.85	2.625	2-13/16	.781	.97	1.03	2,600

\*Socket Depth

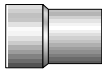
**NOTE:** Other drop sizes available upon request.  
Dimensions for reference only, subject to change.

# Weld-Iok<sup>®</sup> Socket Weld Tube Fittings

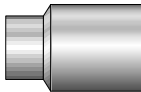
## Adapter

**AW** • tube socket end – adapter end for welding into a female pipe size welding boss

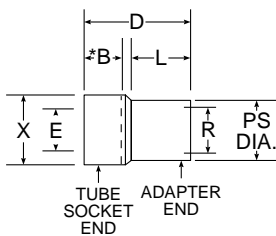
**TYPE I**



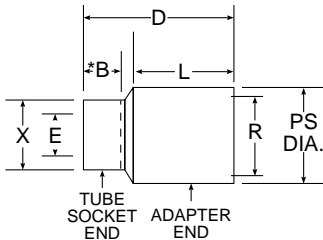
**TYPE II**



**TYPE I**



**TYPE II**



PART NO.	TYPE	TUBE O.D.	PIPE SIZE	PIPE SIZE O.D.	R BORE	X DIA.	L	D	*B	E BORE	WORK PRES.
2-1/8 AW	II	1/8	1/8	.41	.21	.38	.38	.73	.16	.09	8,700
2-1/4 AW	II	1/8	1/4	.54	.30	.38	.56	.95	.16	.09	8,200
3-1/8 AW	I	3/16	1/8	.41	.21	.44	.38	.76	.20	.14	8,700
3-1/2 AW	II	3/16	1/2	.84	.55	.44	.75	1.26	.20	.14	6,400
3-3/4 AW	II	3/16	3/4	1.05	.73	.44	.75	1.32	.20	.14	5,300
4-1/8 AW	I	1/4	1/8	.41	.21	.50	.38	.84	.25	.19	8,700
4-1/4 AW	II	1/4	1/4	.54	.30	.50	.56	1.01	.25	.19	8,200
4-3/8 AW	II	1/4	3/8	.68	.42	.50	.56	1.05	.25	.19	6,900
4-1/2 AW	II	1/4	1/2	.84	.55	.50	.75	1.29	.25	.19	6,400
4-3/4 AW	II	1/4	3/4	1.05	.73	.50	.75	1.35	.25	.19	5,300
4-1 AW	II	1/4	1	1.31	.95	.50	.94	1.61	.25	.19	4,900
5-1/8 AW	I	5/16	1/8	.41	.21	.59	.38	.93	.31	.21	8,700
5-1/2 AW	II	5/16	1/2	.84	.55	.59	.75	1.32	.31	.25	6,400
6-1/4 AW	I	3/8	1/4	.54	.30	.63	.56	1.12	.34	.30	8,100
6-3/8 AW	II	3/8	3/8	.68	.42	.63	.56	1.11	.34	.31	6,900
6-1/2 AW	II	3/8	1/2	.84	.55	.63	.75	1.34	.34	.31	6,400
6-3/4 AW	II	3/8	3/4	1.05	.73	.63	.75	1.40	.34	.31	5,300
6-1 AW	II	3/8	1	1.31	.95	.63	.94	1.67	.34	.31	4,900
6-1-1/2 AW	II	3/8	1-1/2	1.50	1.50	.63	1.03	1.93	.34	.31	3,700
8-1/4 AW	I	1/2	1/4	.54	.30	.78	.56	1.23	.41	.30	8,100
8-3/8 AW	I	1/2	3/8	.68	.41	.78	.56	1.19	.41	.41	6,900
8-1/2 AW	II	1/2	1/2	.84	.55	.78	.75	1.36	.41	.44	6,400
8-3/4 AW	II	1/2	3/4	1.05	.73	.78	.75	1.42	.41	.44	5,300
8-1 AW	II	1/2	1	1.31	.95	.78	.94	1.69	.41	.44	4,900
10-1/2 AW	I	5/8	1/2	.84	.55	.94	.75	1.43	.47	.50	4,900
10-3/4 AW	II	5/8	3/4	1.05	.73	.94	.75	1.44	.47	.50	5,300
10-1 AW	II	5/8	1	1.31	.95	.94	.94	1.70	.47	.50	4,900
12-1/4 AW	I	3/4	1/4	.54	.30	1.09	.56	1.41	.50	.30	6,000
12-3/8 AW	I	3/4	3/8	.68	.42	1.09	.56	1.37	.50	.42	6,000
12-1/2 AW	I	3/4	1/2	.84	.55	1.09	.75	1.51	.50	.55	6,000
12-3/4 AW	I	3/4	3/4	1.05	.73	1.09	.75	1.45	.50	.66	5,300
12-1 AW	II	3/4	1	1.31	.95	1.09	.94	1.69	.50	.66	4,900
16-1/4 AW	I	1	1/4	.54	.30	1.44	.56	1.57	.56	.30	4,900
16-3/8 AW	I	1	3/8	.68	.42	1.44	.56	1.53	.56	.42	4,900
16-1/2 AW	I	1	1/2	.84	.55	1.44	.75	1.67	.56	.55	4,900
16-3/4 AW	I	1	3/4	1.05	.73	1.44	.75	1.61	.56	.73	4,900
16-1 AW	I	1	1	1.31	.95	1.44	.94	1.72	.56	.91	4,900
16-1-1/4 AW	II	1	1-1/4	1.66	1.28	1.44	.94	1.75	.56	.91	4,100
16-1-1/2 AW	II	1	1-1/2	1.90	1.50	1.44	1.03	1.91	.56	.91	3,700
20-1-1/4 AW	II	1-1/4	1-1/4	1.66	1.28	1.75	.94	1.78	.63	1.06	4,100
20-1-1/2 AW	II	1-1/4	1-1/2	1.90	1.50	1.75	1.03	1.89	.63	1.06	3,700
24-1-1/2 AW	I	1-1/2	1-1/2	1.90	1.50	2.00	1.03	1.92	.67	1.31	3,700
32-2 AW	I	2	2	2.38	1.94	2.63	1.06	2.10	.78	1.81	3,200

**NOTE:** "R" bore diameter will conform to Schedule 80 pipe wall thickness unless otherwise noted.

\*Socket Depth

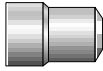
**NOTE:** Other drop sizes available upon request.  
Dimensions for reference only, subject to change.

# Weld-lok® Socket Weld Tube Fittings

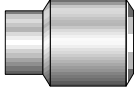
## Adapter

AW2 • tube socket to pipe butt weld

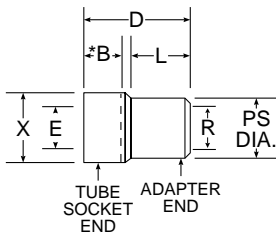
TYPE I



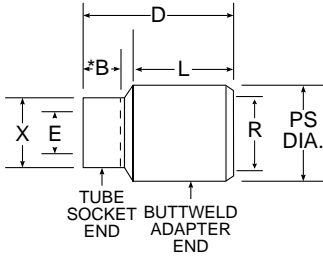
TYPE II



TYPE I



TYPE II



PART NO.	TYPE	TUBE O.D.	PIPE SIZE	PIPE SIZE O.D.	R BORE	X DIA.	L	D	*B	E BORE	WORK. PRES.
2-1/8 AW2	II	1/8	1/8	.41	.21	.38	.38	.73	.16	.09	8,700
2-1/4 AW2	II	1/8	1/4	.54	.30	.38	.56	.95	.16	.09	8,200
3-1/8 AW2	I	3/16	1/8	.41	.21	.44	.38	.76	.20	.14	8,700
3-1/2 AW2	II	3/16	1/2	.84	.55	.44	.75	1.26	.20	.14	6,400
3-3/4 AW2	II	3/16	3/4	1.05	.73	.44	.75	1.32	.20	.14	5,300
4-1/8 AW2	I	1/4	1/8	.41	.21	.50	.38	.84	.25	.19	8,700
4-1/4 AW2	II	1/4	1/4	.54	.30	.50	.56	1.01	.25	.19	8,200
4-3/8 AW2	II	1/4	3/8	.68	.42	.50	.56	1.05	.25	.19	6,900
4-1/2 AW2	II	1/4	1/2	.84	.55	.50	.75	1.29	.25	.19	6,400
4-3/4 AW2	II	1/4	3/4	1.05	.73	.50	.75	1.35	.25	.19	5,300
4-1 AW2	II	1/4	1	1.31	.95	.50	.94	1.61	.25	.19	4,900
5-1/8 AW2	I	5/16	1/8	.41	.21	.59	.38	.93	.31	.21	8,700
5-1/2 AW2	II	5/16	1/2	.84	.55	.59	.75	1.32	.31	.25	6,400
6-1/4 AW2	I	3/8	1/4	.54	.30	.63	.56	1.12	.34	.30	8,100
6-3/8 AW2	II	3/8	3/8	.68	.42	.63	.56	1.11	.34	.31	6,900
6-1/2 AW2	II	3/8	1/2	.84	.55	.63	.75	1.34	.34	.31	6,400
6-3/4 AW2	II	3/8	3/4	1.05	.73	.63	.75	1.40	.34	.31	5,300
6-1 AW2	II	3/8	1	1.31	.95	.63	.94	1.67	.34	.31	4,900
6-1-1/2 AW2	II	3/8	1-1/2	1.50	1.50	.63	1.03	1.93	.34	.31	3,700
8-1/4 AW2	I	1/2	1/4	.54	.30	.78	.56	1.23	.41	.30	8,100
8-3/8 AW2	I	1/2	3/8	.68	.41	.78	.56	1.19	.41	.41	6,900
8-1/2 AW2	II	1/2	1/2	.84	.55	.78	.75	1.36	.41	.44	6,400
8-3/4 AW2	II	1/2	3/4	1.05	.78	.75	1.42	.41	.44	.44	5,300
8-1 AW2	II	1/2	1	1.31	.95	.78	.94	1.69	.41	.44	4,900
10-1/2 AW2	I	5/8	1/2	.54	.30	.94	.75	1.43	.47	.50	4,900
10-3/4 AW2	II	5/8	3/4	1.05	.73	.94	.75	1.44	.47	.50	5,300
10-1 AW2	II	5/8	1	1.31	.95	.94	.94	1.70	.47	.50	4,900
12-1/4 AW2	I	3/4	1/4	.54	.30	1.09	.56	1.41	.50	.30	6,000
12-3/8 AW2	I	3/4	3/8	.68	.42	1.09	.56	1.37	.50	.42	6,000
12-1/2 AW2	I	3/4	1/2	.84	.55	1.09	.75	1.51	.50	.55	6,000
12-3/4 AW2	I	3/4	3/4	1.05	.73	1.09	.75	1.45	.50	.66	5,300
12-1 AW2	II	3/4	1	1.31	.95	1.09	.94	1.69	.50	.66	4,900
16-1/4 AW2	I	1	1/4	.54	.30	1.44	.56	1.57	.56	.30	4,900
16-3/8 AW2	I	1	3/8	.68	.42	1.44	.56	1.53	.56	.42	4,900
16-1/2 AW2	I	1	1/2	.84	.55	1.44	.75	1.67	.56	.55	4,900
16-3/4 AW2	I	1	3/4	1.05	.73	1.44	.75	1.61	.56	.73	4,900
16-1 AW2	I	1	1	1.31	.95	1.44	.94	1.72	.56	.91	4,900
16-1-1/4 AW2	II	1	1-1/4	1.66	1.28	1.44	.94	1.75	.56	.91	4,100
16-1-1/2 AW2	II	1	1-1/2	1.90	1.50	1.44	1.03	1.91	.56	.91	3,700
20-1-1/4 AW2	II	1-1/4	1-1/4	1.66	1.28	1.75	.94	1.78	.63	1.06	4,100
20-1-1/2 AW2	II	1-1/4	1-1/2	1.90	1.50	1.75	1.03	1.89	.63	1.06	3,700
24-1-1/2 AW2	I	1-1/2	1-1/2	1.90	1.50	2.00	1.03	1.92	.67	1.31	3,700
32-2 AW2	I	2	2	2.38	1.94	2.63	1.06	2.10	.78	1.81	3,200

**NOTE:** "R" bore diameter will conform to Schedule 80 pipe wall thickness unless otherwise noted.

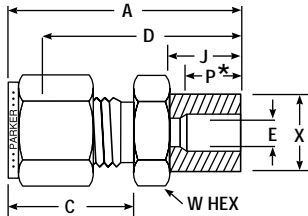
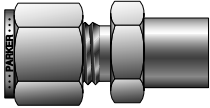
\*Socket Depth

**NOTE:** Other drop sizes available upon request.  
Dimensions for reference only, subject to change.

## ZHBW

Socket weld connector for fractional tube

- for CPI™ to tubing socket weld connection



PART NO.	INTER-CHANGES WITH	TUBE O.D.	A	C	D	J	*P	X	E BORE	W HEX
1-2 ZHBW	100-6-2W	1/16	.99	.43	.84	.34	.16	.38	.09	7/16
1-4 ZHBW	100-6-4W	1/16	1.10	.43	.95	.44	.25	.50	.19	9/16
2-2 ZHBW	200-6-2W	1/8	1.16	.60	.90	.34	.16	.38	.09	7/16
3-3 ZHBW	300-6-3W	3/16	1.25	.64	.98	.39	.20	.44	.13	1/2
4-4 ZHBW	400-6-4W	1/4	1.37	.70	1.08	.44	.25	.50	.19	9/16
4-6 ZHBW	400-6-6W	1/4	1.47	.70	1.18	.53	.34	.63	.31	11/16
4-8 ZHBW	400-6-8W	1/4	1.56	.70	1.27	.59	.41	.78	.44	13/16
4-10 ZHBW	400-6-10W	1/4	1.60	.70	1.31	.66	.47	.94	.50	1
4-12 ZHBW	400-6-12W	1/4	1.75	.70	1.46	.69	.50	1.09	.66	1-1/8
4-16 ZHBW	400-6-16W	1/4	1.88	.70	1.59	.75	.56	1.38	.91	1-1/2
6-2 ZHBW	600-6-2W	3/8	1.35	.76	1.06	.34	.16	.38	.09	5/8
6-6 ZHBW	600-6-6W	3/8	1.53	.76	1.24	.53	.34	.63	.28	11/16
6-8 ZHBW	600-6-8W	3/8	1.63	.76	1.34	.59	.41	.78	.44	13/16
6-12 ZHBW	600-6-12W	3/8	1.81	.76	1.52	.69	.50	1.09	.66	1-1/8
6-16 ZHBW	600-6-16W	3/8	2.02	.76	1.73	.75	.56	1.44	.91	1-5/8
8-2 ZHBW	800-6-2W	1/2	1.49	.87	1.09	.34	.16	.38	.09	13/16
8-4 ZHBW	800-6-4W	1/2	1.58	.87	1.18	.44	.25	.50	.19	13/16
8-6 ZHBW	800-6-6W	1/2	1.67	.87	1.27	.53	.34	.63	.31	13/16
8-8 ZHBW	800-6-8W	1/2	1.74	.87	1.34	.59	.41	.78	.41	13/16
8-12 ZHBW	800-6-12W	1/2	1.92	.87	1.52	.69	.50	1.09	.66	1-1/8
8-16 ZHBW	800-6-16W	1/2	2.53	.87	1.73	.75	.56	1.44	.91	1-5/8
10-10 ZHBW	1010-6-10W	5/8	1.86	.87	1.46	.66	.47	.94	.50	1
10-12 ZHBW	1010-6-12W	5/8	1.92	.87	1.52	.69	.50	1.09	.66	1-1/8
12-4 ZHBW	1210-6-4W	3/4	1.68	.87	1.28	.44	.25	.50	.19	1-1/16
12-8 ZHBW	1210-6-8W	3/4	1.84	.87	1.44	.59	.41	.78	.44	1-1/16
12-12 ZHBW	1210-6-12W	3/4	1.92	.87	1.52	.69	.50	1.09	.63	1-1/8
12-16 ZHBW	1210-6-16W	3/4	2.13	.87	1.73	.75	.56	1.44	.91	1-5/8
16-4 ZHBW	1610-6-4W	1	1.95	1.05	1.46	.44	.25	.50	.19	1-3/8
16-6 ZHBW	1610-6-6W	1	2.05	1.05	1.56	.53	.34	.63	.31	1-3/8
16-12 ZHBW	1610-6-12W	1	2.20	1.05	1.71	.69	.50	1.09	.66	1-3/8
16-16 ZHBW	1610-6-16W	1	2.31	1.05	1.82	.75	.56	1.44	.88	1-5/8
16-20 ZHBW	1610-6-20W	1	2.43	1.05	1.94	.81	.63	1.75	.88	1-7/8
20-16 ZHBW	2000-6-16W	1-1/4	2.81	1.52	1.95	.75	.56	1.44	.91	1-3/4
20-20 ZHBW	2000-6-20W	1-1/4	2.90	1.52	2.04	.81	.63	1.75	1.09	1-7/8
24-12 ZHBW	2400-6-12W	1-1/2	3.15	1.77	2.09	.69	.50	1.09	.66	2-1/8
24-20 ZHBW	2400-6-20W	1-1/2	3.27	1.77	2.21	.81	.63	1.75	1.06	2-1/8
24-24 ZHBW	2400-6-24W	1-1/2	3.32	1.77	2.26	.86	.67	2.00	1.31	2-1/8
32-32 ZHBW	3200-6-32W	2	4.40	2.47	2.93	.97	.78	2.63	1.81	2-3/4

**NOTE:** A and C dimensions are typical finger-tight.

Dimensions for reference only, subject to change.

For A-LOK® tube fitting double ferrule system replace "B" (ZHBW) with a "L" (ZHLW)

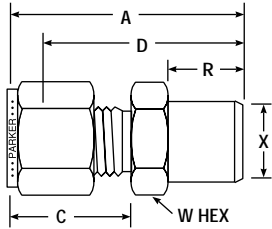
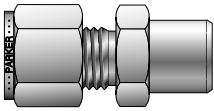
\*Socket Depth

# Weld-lok® To Compression

## ZHBW2

Buttweld connector for fractional pipe

• for CPI™ to pipe buttweld connection



PART NO.	INTER-CHANGES WITH	TUBE O.D.	BUTT-WELD PIPE SIZE	A	C	D	R	X	BUTT-WELD O.D.	W HEX
1-1/8 ZHBW2	00-1-2W	1/16	1/8	1.03	.43	.88	.38	.41	7/16	7/16
2-1/8 ZHBW2	200-1-2W	1/8	1/8	1.20	.60	.94	.38	.41	7/16	7/16
2-1/4 ZHBW2	200-1-4W	1/8	1/4	1.40	.60	1.14	.56	.54	9/16	9/16
2-1/2 ZHBW2	200-1-8W	1/8	1/2	1.67	.60	1.41	.75	.84	7/8	7/8
3-1/8 ZHBW2	300-1-2W	3/16	1/8	1.24	.64	.97	.38	.41	7/16	7/16
4-1/8 ZHBW2	400-1-2W	1/4	1/8	1.29	.70	1.00	.38	.41	1/2	1/2
4-1/4 ZHBW2	400-1-4W	1/4	1/4	1.50	.70	1.20	.56	.54	5/8	5/8
4-3/8 ZHBW2	400-1-6W	1/4	3/8	1.54	.70	1.25	.56	.68	3/4	3/4
4-1/2 ZHBW2	400-1-8W	1/4	1/2	1.76	.70	1.47	.75	.84	7/8	7/8
4-3/4 ZHBW2	400-1-12W	1/4	3/4	1.82	.70	1.53	.75	1.05	1-1/8	1-1/8
4-1 ZHBW2	400-1-16W	1/4	1	2.10	.70	1.81	.94	1.32	1-3/8	1-3/8
5-1/8 ZHBW2	500-1-2W	5/16	1/8	1.34	.73	1.05	.38	.41	9/16	9/16
5-1/4 ZHBW2	500-1-4W	5/16	1/4	1.52	.73	1.23	.56	.54	9/16	9/16
5-1/2 ZHBW2	500-1-8W	5/16	1/2	1.79	.73	1.500	.75	.84	7/8	7/8
6-1/4 ZHBW2	600-1-4W	3/8	1/4	1.57	.76	1.28	.56	.54	5/8	5/8
6-3/8 ZHBW2	600-1-6W	3/8	3/8	1.57	.76	1.28	.56	.68	3/4	3/4
6-1/2 ZHBW2	600-1-8W	3/8	1/2	1.82	.76	1.53	.75	.84	7/8	7/8
6-3/4 ZHBW2	600-1-12W	3/8	3/4	1.88	.76	1.59	.75	1.05	1-1/8	1-1/8
6-1 ZHBW2	600-1-16W	3/8	1	2.17	.76	1.88	.94	1.32	1-3/8	1-3/8
6-1-1/2 ZHBW2	600-1-24W	3/8	1-1/2	2.39	.76	2.10	1.03	1.90	2	2
6-2 ZHBW2	600-1-32W	3/8	2	2.58	.76	2.29	1.06	2.38	2-1/2	2-1/2
8-1/8 ZHBW2	810-1-2W	1/2	1/8	1.53	.87	1.13	.38	.41	13/16	13/16
8-1/4 ZHBW2	810-1-4W	1/2	1/4	1.71	.87	1.31	.56	.54	13/16	13/16
8-3/8 ZHBW2	810-1-6W	1/2	3/8	1.71	.87	1.31	.56	.68	13/16	13/16
8-1/2 ZHBW2	810-1-8W	1/2	1/2	1.93	.87	1.53	.75	.84	7/8	7/8
8-3/4 ZHBW2	810-1-12W	1/2	3/4	1.99	.87	1.59	.75	1.05	1-1/8	1-1/8
8-1 ZHBW2	81-1-16W	1/2	1	2.28	.87	1.88	.94	1.32	1-3/8	1-3/8
8-1-1/2 ZHBW2	810-1-24W	1/2	1-1/2	2.50	.87	2.10	1.03	1.90	2	2
10-1/4 ZHBW2	1010-1-4W	5/8	1/4	1.74	.87	1.34	.56	.54	15/16	15/16
10-3/8 ZHBW2	1010-1-6W	5/8	3/8	1.74	.87	1.34	.56	.67	15/16	15/16
10-1/2 ZHBW2	1010-1-8W	5/8	1/2	1.93	.87	1.53	.75	.84	15/16	15/16
10-3/4 ZHBW2	1010-1-12W	5/8	3/4	1.99	.87	1.59	.75	1.05	1-1/8	1-1/8
12-3/8 ZHBW2	1210-1-6W	3/4	3/8	1.81	.87	1.41	.56	.67	1-1/8	1-1/8
12-1/2 ZHBW2	1210-1-8W	3/4	1/2	1.99	.87	1.59	.75	.84	1-1/8	1-1/8
12-3/4 ZHBW2	1210-1-12W	3/4	3/4	1.99	.87	1.59	.75	1.05	1-1/8	1-1/8
12-1 ZHBW2	1210-1-16W	3/4	1	2.28	.87	1.88	.94	1.32	1-3/8	1-3/8
16-1/2 ZHBW2	1610-1-8W	1	1/2	2.18	1.05	1.78	.75	.84	1-3/8	1-3/8
16-3/4 ZHBW2	1610-1-12W	1	3/4	2.27	1.05	1.78	.75	1.05	1-3/8	1-3/8
16-1 ZHBW2	1610-1-16W	1	1	2.46	1.05	1.97	.94	1.32	1-3/8	1-3/8
16-1-1/4 ZHBW2	1610-1-20W	1	1-1/4	2.56	1.05	2.07	.94	1.66	1-3/4	1-3/4
16-1-1/2 ZHBW2	1610-1-24W	1	1-1/2	2.68	1.05	2.19	1.03	1.90	2	2
20-1 ZHBW2	2000-1-16W	1-1/4	1	3.06	1.52	2.20	.94	1.32	1-3/4	1-3/4
20-1-1/4 ZHBW2	2000-1-20W	1-1/4	1-1/4	3.03	1.52	2.17	.94	1.66	1-3/4	1-3/4
20-1-1/2 ZHBW2	2000-1-24W	1-1/4	1-1/2	3.16	1.52	2.30	1.03	1.90	2	2
24-1 ZHBW2	2400-1-16W	1-1/2	1	3.50	1.77	2.44	.94	1.32	2-1/8	2-1/8
24-1-1/4 ZHBW2	2400-1-20W	1-1/2	1-1/4	3.36	1.77	2.30	.94	1.66	2-1/8	2-1/8
24-1-1/2 ZHBW2	2400-1-24W	1-1/2	1-1/2	3.50	1.77	2.44	1.03	1.90	2-1/8	2-1/8
32-2 ZHBW2	3200-1-32W	2	2	4.47	2.47	3.00	1.06	2.38	2-3/4	2-3/4

**NOTE:** A and C dimensions are typical finger-tight.

Dimensions for reference only, subject to change.

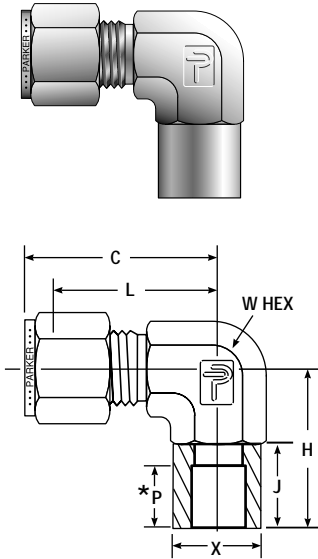
Pipe Buttweld end will conform to Schedule 80 unless otherwise noted.

For A-LOK® tube fitting double ferrule system replace "B" (ZHBW2) with a "L" (ZHLW2)

## ZEBW

For fractional tube

- for CPI™ to tubing socket weld connection



PART NO.	INTERCHANGES WITH	TUBE O.D.	C	L	H	J	*P	X DIA.	W HEX
2-2 ZEBW	200-9-2W	1/8	.93	.70	.70	.34	.16	.38	1/2
3-3 ZEBW	300-9-3W	3/16	1.01	.74	.75	.39	.20	.44	1/2
4-4 ZEBW	400-9-4W	1/4	1.07	.78	.78	.44	.25	.50	9/16
6-6 ZEBW	600-9-6W	3/8	1.31	1.02	1.08	.53	.34	.63	3/4
6-12 ZEBW	600-9-12W	3/8	1.46	1.17	1.39	.69	.50	1.09	1-1/16
6-16 ZEBW	600-9-16W	3/8	1.84	1.55	1.84	.75	.56	1.44	1-5/8
8-4 ZEBW	800-9-4W	1/2	1.42	1.02	.99	.44	.25	.50	13/16
8-8 ZEBW	800-9-8W	1/2	1.42	1.02	1.14	.59	.41	.78	13/16
8-10 ZEBW	800-9-10W	1/2	1.57	1.17	1.36	.66	.47	.94	1-1/16
8-12 ZEBW	800-9-12W	1/2	1.57	1.17	1.34	.69	.50	1.09	1-1/16
8-16 ZEBW	800-9-16W	1/2	1.95	1.55	1.84	.75	.56	1.44	1-5/8
10-6 ZEBW	1010-9-6W	5/8	1.50	1.10	1.16	.53	.34	.63	15/16
10-8 ZEBW	1010-9-8W	5/8	1.50	1.10	1.22	.59	.41	.78	15/16
10-10 ZEBW	1010-9-10W	5/8	1.57	1.17	1.36	.66	.47	.94	1-1/16
10-16 ZEBW	1010-9-16W	5/8	1.95	1.55	1.84	.75	.56	1.44	1-5/8
12-12 ZEBW	1210-9-12W	3/4	1.57	1.17	1.39	.69	.50	1.09	1-1/16
14-12 ZEBW	1410-9-12W	7/8	1.76	1.36	1.58	.69	.50	1.09	1-3/8
16-14 ZEBW	1610-9-14W	1	1.94	1.45	1.58	.69	.50	1.31	1-3/8
16-16 ZEBW	1610-9-16W	1	2.14	1.65	1.84	.75	.56	1.44	1-5/8

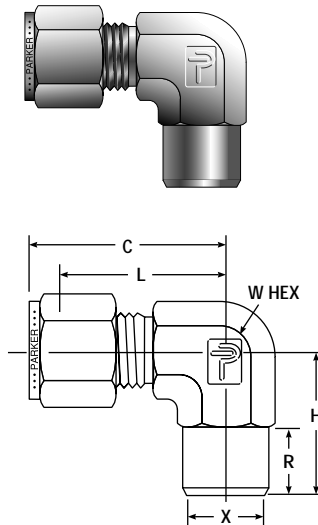
**NOTE:** C dimension is typical finger-tight. Dimensions for reference only, subject to change. For A-LOK® tube fitting double ferrule system replace "B" (ZEBW) with a "L" (ZHLW)

\*Socket Depth

## ZEBW2

Buttweld elbow for fractional pipe

- for CPI™ to pipe connection



PART NO.	INTERCHANGES WITH	TUBE O.D.	BUTT-WELD PIPE SIZE	C	H	L	R	X BUTT-WELD O.D.	W HEX
2-1/8 ZEBW2	200-2-2W	1/8	1/8	.93	.70	.67	.38	.41	7/16
3-1/8 ZEBW2	300-2-2W	3/16	1/8	1.01	.74	.74	.38	.41	1/2
4-1/8 ZEBW2	400-2-2W	1/4	1/8	1.06	.74	.77	.38	.41	1/2
4-1/4 ZEBW2	400-2-4W	1/4	1/4	1.10	.97	.81	.56	.54	9/16
4-3/4 ZEBW2	400-2-12W	1/4	3/4	1.40	1.45	1.11	.75	1.05	1-1/16
6-1/4 ZEBW2	600-2-4W	3/8	1/4	1.20	1.00	.91	.56	.54	5/8
6-3/8 ZEBW2	600-2-6W	3/8	3/8	1.31	1.11	1.02	.56	.68	13/16
6-1/2 ZEBW2	600-2-8W	3/8	1/2	1.31	1.30	1.02	.75	.84	7/8
6-3/4 ZEBW2	600-2-12W	3/8	3/4	1.46	1.45	1.17	.75	1.05	1-1/16
6-1 ZEBW2	600-2-16W	3/8	1	1.65	1.83	1.36	.94	1.32	1-3/8
8-1/4 ZEBW2	810-2-4W	1/2	1/4	1.42	1.11	1.02	.56	.54	13/16
8-3/8 ZEBW2	810-2-6W	1/2	3/8	1.42	1.11	1.02	.56	.68	13/16
8-1/2 ZEBW2	810-2-8W	1/2	1/2	1.42	1.30	1.02	.75	.84	7/8
8-3/4 ZEBW2	810-2-12W	1/2	3/4	1.57	1.45	1.17	.75	1.05	1-1/16
8-1 ZEBW2	810-W-16W	1/2	1	1.76	1.86	1.36	.94	1.32	1-3/8
10-1/2 ZEBW2	1010-2-8W	5/8	1/2	1.50	1.39	1.10	.75	.84	15/16
12-1/2 ZEBW2	1210-2-8W	3/4	1/2	1.66	1.45	1.26	.75	.84	1-1/16
12-3/4 ZEBW2	1210-2-12W	3/4	3/4	1.57	1.45	1.17	.75	1.05	1-1/16
14-3/4 ZEBW2	1410-2-12W	7/8	3/4	1.78	1.64	1.36	.75	1.05	1-3/8
14-1 ZEBW2	1410-W-16W	7/8	1	1.78	1.83	1.36	.94	1.32	1-3/8
16-1/2 ZEBW2	1610-2-8W	1	1/2	1.94	1.64	1.45	.75	.84	1-3/8
16-3/4 ZEBW2	1610-2-12W	1	3/4	1.94	1.64	1.45	.75	1.05	1-3/8
16-1 ZEBW2	1610-2-16W	1	1	1.94	1.83	1.45	.94	1.32	1-3/8
16-1-1/4 ZEBW2	1610-2-20W	1	1-1/4	2.14	1.88	1.65	.94	1.66	1-5/8
20-1-1/4 ZEBW2	2000-2-20W	1-1/4	1-1/4	2.61	2.02	1.75	.94	1.66	1-5/8
24-1-1/2 ZEBW2	2400-2-24W	1-1/2	1-1/2	3.06	2.38	2.00	1.03	1.90	1-7/8

**NOTE:** C dimension is typical finger-tight. Dimensions for reference only, subject to change. Pipe buttweld end will conform to Schedule 80 unless otherwise noted.

For A-LOK® tube fitting double ferrule system replace "B" (ZEBW2) with a "L" (ZELW2)